

COM-HPC Server Evaluation Carrier

Rev. 1.1

This page has been intentionally left blank

 COM-HPC SERVER EVALUATION CARRIER – USER GUIDE

Disclaimer

JUMPttec would like to point out that the information contained in this user guide may be subject to alteration, particularly as a result of the constant upgrading of JUMPttec products. This document does not entail any guarantee on the part of JUMPttec with respect to technical processes described in the user guide or any product characteristics set out in the user guide. JUMPttec assumes no responsibility or liability for the use of the described product(s), conveys no license or title under any patent, copyright or mask work rights to these products and makes no representations or warranties that these products are free from patent, copyright or mask work right infringement unless otherwise specified. Applications that are described in this user guide are for illustration purposes only. JUMPttec makes no representation or warranty that such application will be suitable for the specified use without further testing or modification. JUMPttec expressly informs the user that this user guide only contains a general description of processes and instructions which may not be applicable in every individual case. In cases of doubt, please contact JUMPttec.

This user guide is protected by copyright. All rights are reserved by JUMPttec. No part of this document may be reproduced, transmitted, transcribed, stored in a retrieval system, or translated into any language or computer language, in any form or by any means (electronic, mechanical, photocopying, recording, or otherwise), without the express written permission of JUMPttec. JUMPttec points out that the information contained in this user guide is constantly being updated in line with the technical alterations and improvements made by JUMPttec to the products and thus this user guide only reflects the technical status of the products by JUMPttec at the time of publishing.

Brand and product names are trademarks or registered trademarks of their respective owners.

©2025 by JUMPttec GmbH

JUMPttec GmbH
Brunnwiesenstrasse 16
94469 Deggendorf
Germany
www.jumpotec.com

Intended Use

THIS DEVICE AND ASSOCIATED SOFTWARE ARE NOT DESIGNED, MANUFACTURED OR INTENDED FOR USE OR RESALE FOR THE OPERATION OF NUCLEAR FACILITIES, THE NAVIGATION, CONTROL OR COMMUNICATION SYSTEMS FOR AIRCRAFT OR OTHER TRANSPORTATION, AIR TRAFFIC CONTROL, LIFE SUPPORT OR LIFE SUSTAINING APPLICATIONS, WEAPONS SYSTEMS, OR ANY OTHER APPLICATION IN A HAZARDOUS ENVIRONMENT, OR REQUIRING FAIL-SAFE PERFORMANCE, OR IN WHICH THE FAILURE OF PRODUCTS COULD LEAD DIRECTLY TO DEATH, PERSONAL INJURY, OR SEVERE PHYSICAL OR ENVIRONMENTAL DAMAGE (COLLECTIVELY, "HIGH RISK APPLICATIONS").

You understand and agree that your use of JUMPtec devices as a component in High Risk Applications is entirely at your risk. To minimize the risks associated with your products and applications, you should provide adequate design and operating safeguards. You are solely responsible for compliance with all legal, regulatory, safety, and security related requirements concerning your products. You are responsible to ensure that your systems (and any JUMPtec hardware or software components incorporated in your systems) meet all applicable requirements. Unless otherwise stated in the product documentation, the JUMPtec device is not provided with error-tolerance capabilities and cannot therefore be deemed as being engineered, manufactured or setup to be compliant for implementation or for resale as device in High Risk Applications. All application and safety related information in this document (including application descriptions, suggested safety measures, suggested JUMPtec products, and other materials) is provided for reference only.

CAUTION

Handling and operation of the product is permitted only for trained personnel within a work place that is access controlled. Please follow the "General Safety Instructions" supplied with the system.

NOTICE

You find the most recent version of the "General Safety Instructions" online in the download area of this product on the [JUMPtec website](#).

NOTICE

This product is not suited for storage or operation in corrosive environments, in particular under exposure to sulfur and chlorine and their compounds. For information on how to harden electronics and mechanics against these stress conditions, contact JUMPtec Support.

Revision History

Revision	Brief Description of Changes	Date of Issue	Author
1.0	Initial release	2023-August 11	IH
1.1	New product picture - JUMPttec update	2025-January-28	IH

Terms and Conditions

JUMPttec warrants products in accordance with defined regional warranty periods. For more information about warranty compliance and conformity, and the warranty period in your region, visit <https://www.jumpotec.com/en/terms-and-conditions>.

JUMPttec sells products worldwide and declares regional General Terms & Conditions of Sale, and Purchase Order Terms & Conditions. Visit <https://www.jumpotec.com/en/terms-and-conditions>.

For contact information, refer to the corporate offices contact information on the last page of this user guide or visit our website [CONTACT US](#).

Customer Support

Find JUMPttec contacts by visiting: <https://www.jumpotec.com/en/service-support>.

Customer Service

As a trusted technology innovator and global solutions provider, JUMPttec extends its embedded market strengths into a services portfolio allowing companies to break the barriers of traditional product lifecycles. Proven product expertise coupled with collaborative and highly-experienced support enables JUMPttec to provide exceptional peace of mind to build and maintain successful products.

For more details on JUMPttec's service offerings such as: enhanced repair services, extended warranty, JUMPttec training academy, and more visit <https://www.jumpotec.com/en/service-support>.

Customer Comments

If you have any difficulties using this user guide, discover an error, or just want to provide some feedback, contact [JUMPttec Support](#). Detail any errors you find. We will correct the errors or problems as soon as possible and post the revised user guide on our website.

Symbols

The following symbols may be used in this user guide

⚠ DANGER

DANGER indicates a hazardous situation which, if not avoided, will result in death or serious injury.

⚠ WARNING

WARNING indicates a hazardous situation which, if not avoided, could result in death or serious injury.

NOTICE

NOTICE indicates a property damage message.

⚠ CAUTION

CAUTION indicates a hazardous situation which, if not avoided, may result in minor or moderate injury.



Electric Shock!

This symbol and title warn of hazards due to electrical shocks (> 60 V) when touching products or parts of products. Failure to observe the precautions indicated and/or prescribed by the law may endanger your life/health and/or result in damage to your material.



ESD Sensitive Device!

This symbol and title inform that the electronic boards and their components are sensitive to static electricity. Care must therefore be taken during all handling operations and inspections of this product in order to ensure product integrity at all times.



HOT Surface!

Do NOT touch! Allow to cool before servicing.



Laser!

This symbol inform of the risk of exposure to laser beam and light emitting devices (LEDs) from an electrical device. Eye protection per manufacturer notice shall review before servicing.



This symbol indicates general information about the product and the user guide.

This symbol also indicates detail information about the specific product configuration.



This symbol precedes helpful hints and tips for daily use.

For Your Safety

Your new JUMPtec product was developed and tested carefully to provide all features necessary to ensure its compliance with electrical safety requirements. It was also designed for a long fault-free life. However, the life expectancy of your product can be drastically reduced by improper treatment during unpacking and installation. Therefore, in the interest of your own safety and of the correct operation of your new JUMPtec product, you are requested to conform with the following guidelines.

High Voltage Safety Instructions

As a precaution and in case of danger, the power connector must be easily accessible. The power connector is the product's main disconnect device.

⚠ CAUTION

Warning

All operations on this product must be carried out by sufficiently skilled personnel only.

⚠ CAUTION



Electric Shock!

Before installing a non hot-swappable JUMPtec product into a system always ensure that your mains power is switched off. This also applies to the installation of piggybacks. Serious electrical shock hazards can exist during all installation, repair, and maintenance operations on this product. Therefore, always unplug the power cable and any other cables which provide external voltages before performing any work on this product.

Earth ground connection to vehicle's chassis or a central grounding point shall remain connected. The earth ground cable shall be the last cable to be disconnected or the first cable to be connected when performing installation or removal procedures on this product.

Special Handling and Unpacking Instruction

NOTICE



ESD Sensitive Device!

Electronic boards and their components are sensitive to static electricity. Therefore, care must be taken during all handling operations and inspections of this product, in order to ensure product integrity at all times.

Do not handle this product out of its protective enclosure while it is not used for operational purposes unless it is otherwise protected.

Whenever possible, unpack or pack this product only at EOS/ESD safe work stations. Where a safe work station is not guaranteed, it is important for the user to be electrically discharged before touching the product with his/her hands or tools. This is most easily done by touching a metal part of your system housing.

It is particularly important to observe standard anti-static precautions when changing piggybacks, ROM devices, jumper settings etc. If the product contains batteries for RTC or memory backup, ensure that the product is not placed on conductive surfaces, including anti-static plastics or sponges. They can cause short circuits and damage the batteries or conductive circuits on the product.

Lithium Battery Precautions

If your product is equipped with a lithium battery, take the following precautions when replacing the battery.

⚠ CAUTION

Danger of explosion if the battery is replaced incorrectly.

- ▶ Replace only with same or equivalent battery type recommended by the manufacturer.
 - ▶ Dispose of used batteries according to the manufacturer's instructions.
-

General Instructions on Usage

In order to maintain JUMPtec's product warranty, this product must not be altered or modified in any way. Changes or modifications to the product, that are not explicitly approved by JUMPtec and described in this user guide or received from JUMPtec Support as a special handling instruction, will void your warranty.

This product should only be installed in or connected to systems that fulfill all necessary technical and specific environmental requirements. This also applies to the operational temperature range of the specific board version that must not be exceeded. If batteries are present, their temperature restrictions must be taken into account.

In performing all necessary installation and application operations, only follow the instructions supplied by the present user guide.

Keep all the original packaging material for future storage or warranty shipments. If it is necessary to store or ship the product then re-pack it in the same manner as it was delivered.

Special care is necessary when handling or unpacking the product. See Special Handling and Unpacking Instruction.

Quality and Environmental Management

JUMPtec aims to deliver reliable high-end products designed and built for quality, and aims to complying with environmental laws, regulations, and other environmentally oriented requirements. For more information regarding JUMPtec's quality and environmental responsibilities, visit <https://www.jumptec.com/en/about-jumptec/quality>.

Disposal and Recycling

JUMPtec's products are manufactured to satisfy environmental protection requirements where possible. Many of the components used are capable of being recycled. Final disposal of this product after its service life must be accomplished in accordance with applicable country, state, or local laws or regulations.

WEEE Compliance

The Waste Electrical and Electronic Equipment (WEEE) Directive aims to:

- ▶ Reduce waste arising from electrical and electronic equipment (EEE)
- ▶ Make producers of EEE responsible for the environmental impact of their products, especially when the product become waste
- ▶ Encourage separate collection and subsequent treatment, reuse, recovery, recycling and sound environmental disposal of EEE
- ▶ Improve the environmental performance of all those involved during the lifecycle of EEE



Environmental protection is a high priority with JUMPtec.

JUMPtec follows the WEEE directive

You are encouraged to return our products for proper disposal.

Table of Contents

Symbols.....	6
For Your Safety.....	7
High Voltage Safety Instructions	7
Special Handling and Unpacking Instruction	7
Lithium Battery Precautions	8
General Instructions on Usage	8
Quality and Environmental Management	8
Disposal and Recycling.....	8
WEEE Compliance	8
Table of Contents	9
List of Tables	10
List of Figures	11
1/ Introduction	13
1.1. Product Description	13
1.2. Product Naming Clarification.....	14
2/ System specifications	15
2.1. Main Features.....	15
2.2. Environmental Conditions.....	15
2.3. Block Diagram	16
3/ Mainboard Views.....	17
3.1. Top View.....	17
3.2. Front panel	18
4/ Mechanical Specification.....	19
4.1. Dimensions and Jumper Positions.....	19
5/ Interfaces and Connectors.....	20
5.1. IO Backpanel Board Connector (X4)	20
5.2. Up to 10 GB Ethernet Connector (X31)	21
5.3. USB 3.2 Double Connector (X32, X33)	21
5.4. COM Ports (X35)	22
5.5. BMC Connector (X36)	24
5.6. SATA 6 GB (X18, X19).....	28
5.7. PCIe Slots (X7 – X13)	28
5.8. Fan Connector (X14) and Jumper (X38)	29
5.8.1. Fan Connector with 4 Pins (X14).....	29
5.8.2. Jumper for 5V/12V Fan Selection (X38).....	30
5.9. UART0 BMC Present Header (X15).....	30
5.10. UART – VCC Selection Jumpers (X58, X59)	30
5.11. UART5 Header (X16).....	31
5.12. FW SPI Flash Socket for BMC (X17).....	32
5.13. BIOS Flash Socket (X28).....	32
5.14. BIOS Select Jumper (X37).....	32
5.15. 2x4 SFP28 Cage (X29).....	33
5.16. GPIO - General Purpose Input and Output (X6)	33
5.17. Miscellaneous Header (X40).....	34
5.18. GP_SPI Header (X46)	35
5.19. SUS_S3# / PS_ON Jumper (X39).....	35
5.20. Enable 5V_SBY_HPC Jumper (X47)	35

5.21. Enable VCC_HPC Jumper (X48).....	36
5.22. I2CO Header (X50).....	36
5.23. I2C1 Header (X53).....	36
5.24. SMBus Header (X49).....	37
5.25. SDP Header (X51).....	37
5.26. COM-HPC PICMG EEPROM Header (X52).....	38
5.27. Parade I2C Debug Board Header (X55).....	38
5.28. USB_PD_I2C Header (X57).....	38
5.29. ATX Main Power Connector (X26).....	39
5.30. ATX Power Connector (X27).....	39
5.31. RTC Battery Socket (X45).....	40
5.32. Button Switches (S1 – S5).....	40
5.33. M.2 Key-M Socket (X30, X34).....	41
6/ Electrical Specification.....	43
6.1. Power Supply Rise time.....	43
6.2. Supply Voltage Tolerances.....	43
7/ Features.....	45
7.1. Rapid Shutdown Button (SW5).....	45
7.2. LEDs and Indicators.....	45
7.2.1. Power and Control LEDs.....	45
7.2.2. SFP28 LEDs.....	46
7.2.3. Port 80 BIOS Debug Code Display.....	46
8/ COM-HPC Connector Pin-out List.....	47
9/ Variants.....	53
10/ Technical Support.....	54
10.1. Warranty.....	54
10.2. Returning Defective Merchandise.....	54
11/ List of Acronyms.....	56

List of Tables

Table 1: Main Features.....	15
Table 2: Environmental Conditions.....	15
Table 3: IO Backpanel Board Connector.....	20
Table 4: Max 10 GB Ethernet Connector.....	21
Table 5: Signals.....	21
Table 6: USB 3.2 Double Connector Pinout (X32, X33).....	21
Table 7: Double COM Ports.....	22
Table 8: BMC Connector (X36).....	24
Table 9: SATA 6 GB Connector.....	28
Table 10: PCIe Slots.....	28
Table 11: Fan Connector (X14).....	29
Table 12: Jumper for 5V/12V Fan Selection.....	30
Table 13: BMC Present Jumper (X15).....	30
Table 14: VCC Selection Jumpers (X58, X59).....	30
Table 15: UART5 Header (X16).....	31
Table 16: SPI Flash Socket for BMC.....	32
Table 17: BIOS Flash Socket (X28).....	32
Table 18: BIOS Select Jumper (X37).....	32
Table 19: GPIO Header (X6).....	33
Table 20: Miscellaneous Header (X40).....	34

Table 21: GP_SPI Header (X46).....	35
Table 22: SUS_S3# / PS_ON Jumper (X39).....	35
Table 23: Enable 5V_SBY_HPC Jumper (X47).....	35
Table 24: Enable VCC_HPC Jumper (X48).....	36
Table 25: I2C0 Header (X50).....	36
Table 26: I2C1 Header (X53).....	36
Table 27: SMBus Header (X49).....	37
Table 28: SDP Header (X51).....	37
Table 29: SDP Header (X52).....	38
Table 30: Parade I2C Debug Board Header (X55).....	38
Table 31: USB_PD_I2C Header (X57).....	38
Table 32: ATX Main Power Connector with 24 pins (X26).....	39
Table 33: ATX Power connector with 8 pins (X27).....	39
Table 34: RTC Socket.....	40
Table 35: Control Buttons.....	40
Table 36: Pin Assignment M.2 Connector.....	41
Table 37: Power and Control LEDs.....	45
Table 38: FP28 LEDs.....	46
Table 39: Pin-out List Connector J1.....	47
Table 40: Pin-out List Connector J2.....	49
Table 41: Variants.....	53

List of Figures

Figure 1: COM-HPC Server Evaluation Carrier.....	13
Figure 2: Block Diagram COM-HPC Server Evaluation Carrier.....	16
Figure 3: Top View of COM-HPC Server Evaluation Carrier.....	17
Figure 4: Front Panel.....	18
Figure 5: Board Dimensions and Jumper Positions.....	19
Figure 6: IO Backpanel Board Connector.....	20
Figure 7: USB 3.2 Double Connector (X32, X33).....	21
Figure 8: Double COM Ports.....	22
Figure 9: BMC Connector (X36).....	24
Figure 10: SATA 6 GB.....	28
Figure 11: PCIe x4 Slots.....	29
Figure 12: PCIe x16 and PCIe x8 Slots.....	29
Figure 13: Fan Connector with 4 pins (X14) and Fan Jumper (X38).....	29
Figure 14: BMC Present Jumper (X15) with 3 pins.....	30
Figure 15: UART – VCC Selection Jumpers (X58, X59) with 3 pins.....	30
Figure 16: UART5 Header (X16).....	31
Figure 17: SPI Flash Socket for BMC.....	32
Figure 18: BIOS Flash Socket (X28).....	32
Figure 19: BIOS Select Jumper (X37).....	32
Figure 20: Side View of 2x4 SFP28 Cage (X29).....	33
Figure 21: 2x4 SFP28 Cage (X29) - Block Diagram (Detail).....	33
Figure 22: GPIO Header (X6).....	33
Figure 23: Miscellaneous Header (X40).....	34
Figure 24: GP_SPI Header (X46).....	35
Figure 25: SUS_S3# / PS_ON Jumper (X39).....	35
Figure 26: Enable 5V_SBY_HPC Jumper (X47).....	35
Figure 27: Enable VCC_HPC Jumper (X48).....	36
Figure 28: I2C0 Header, 4-pin (X50).....	36
Figure 29: I2C1 Header, 3-pin (X53).....	36
Figure 30: SMBus Header (X49).....	37
Figure 31: SDP Header (X51).....	37
Figure 32: COM-HPC PICMG EEPROM Header (X52).....	38

Figure 33: Parade I2C Debug Board Header (X55)	38
Figure 34: USB_PD_I2C Header (X57)	38
Figure 35: ATX Main Power Connector (X26)	39
Figure 36: ATX Power connector with 8 pins (X27).....	39
Figure 37: RTC Battery Socket	40
Figure 38: Button Switches	40
Figure 39: M.2 Slot Connector (X30, X34).....	41
Figure 40: Power Diagram.....	44
Figure 41: SFP28 LEDs.....	46
Figure 42: Port 80 BIOS Debug Code 7-Segment Display	46
Figure 43: COM-HPC Connector J1 and J2	47

1/ Introduction

1.1. Product Description

COM-HPC Server Evaluation Carrier is an evaluation, testing and validation carrier board (baseboard) for COM-HPC®/Server modules in E-ATX form factor. Main purpose of this carrier board is to bring out all the signals from the COM-HPC® connector of COM-HPC/Server modules to industry standard interfaces. The key features are:

- ▶ Support of 64 PCIe lanes via various PCIe and M.2 slots
- ▶ 8x SFP28 cages
- ▶ 1x RJ45 – up to 10GBASE-T
- ▶ 4x USB 3.2 Gen2.1
- ▶ 2x SATA
- ▶ Slot for an optional BMC Card
- ▶ BIOS POST-Code display

Figure 1: COM-HPC Server Evaluation Carrier

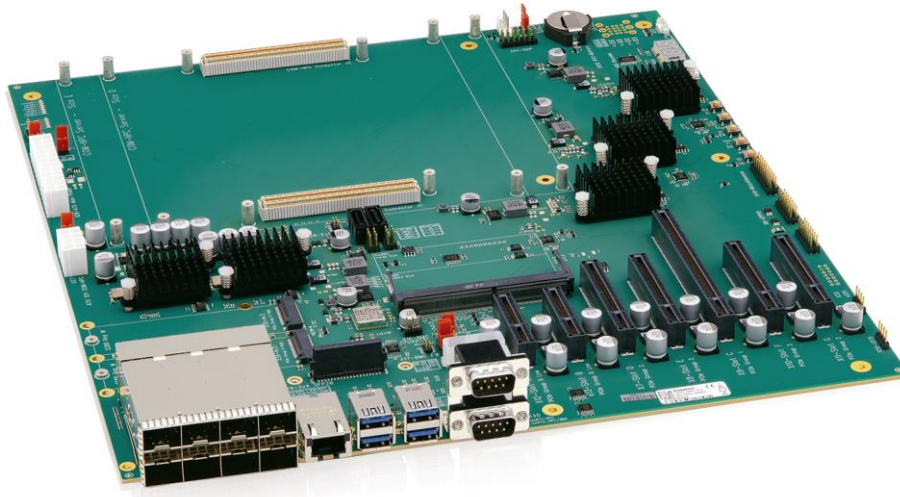

1.2. Product Naming Clarification

COM-HPC® defines a Computer-on-Module, or COM, with all the components necessary for a bootable host computer, packaged as a super component. The product name for JUMPttec COM-HPC® Computer-On-Modules consists of:

Industry standard short form:

- ▶ COMh-

Two different pin-out types:

- ▶ c = client
- ▶ s = server

Module form factor:

- ▶ a = 95 mm x 120 mm
- ▶ b = 120 mm x 120 mm
- ▶ c = 160 mm x 120 mm
- ▶ d = 160 mm x 160 mm
- ▶ e = 200 mm x 160 mm

The COM-HPC Server Evaluation Carrier supports server modules in size D and E.

2/ System specifications

2.1. Main Features

The table below summarizes the features of the evaluation carrier.

Table 1: Main Features

COM-HPC Server Evaluation Carrier	
Dimensions	305 mm x 330 mm (E-ATX)
Ethernet	1x RJ45 – max. 10GBASE-T, 8x SFP28 cages via 2x Intel PHY C827-IM
PCI Express®	2x PCIe Gen4 x4 to 2x PCIe card slots (PCIe Lane Group 0 Low) 2x PCIe Gen3 x4 to 2x M.2 2242/2280 slots (PCIe Lane Group 0 High) 1x PCIe Gen4 x16 slot (PCIe Lane Group 1) 4x PCIe Gen4 x8 to 4x PCIe card slots (PCIe Lane Group 2 and 3)
USB	4x USB 3.2 Gen 2x1
Serial	2x DSUB9 - COM ports (RX/TX)
BMC	1x Slot for optional BMC card
Visual Control BIOS Post-Code	2x 7-segment display, Various LEDs
Onboard Header	2x SATA, 1x I2C, 1x eSPI, 1x SMBus, 1x GPIO, 1x Fan, 1x Feature Connector
Various	BIOS flash-socket, Battery holder
Power Supply	ATX power supply 24 + 8 pin

⚠ CAUTION

Danger of explosion if the lithium battery is replaced incorrectly.

- Replace only with the same or equivalent type recommended by the manufacturer
- Dispose of used batteries according to the manufacturer's instructions

2.2. Environmental Conditions

Table 2: Environmental Conditions

Operating	-0°C to +60°C Some connectors and supercap has operating temperature only 0°C to +70°C, relative humidity (non-condensing) 10 % to 93 % at 40°C
Storage	-30°C to +85°C relative humidity (non-condensing) 10 % to 93 % at 40°C
Theoretical MTBF	not applicable
Compliance	CE/UKCA, RoHS II, WEEE

2.3. Block Diagram

Figure 2: Block Diagram COM-HPC Server Evaluation Carrier

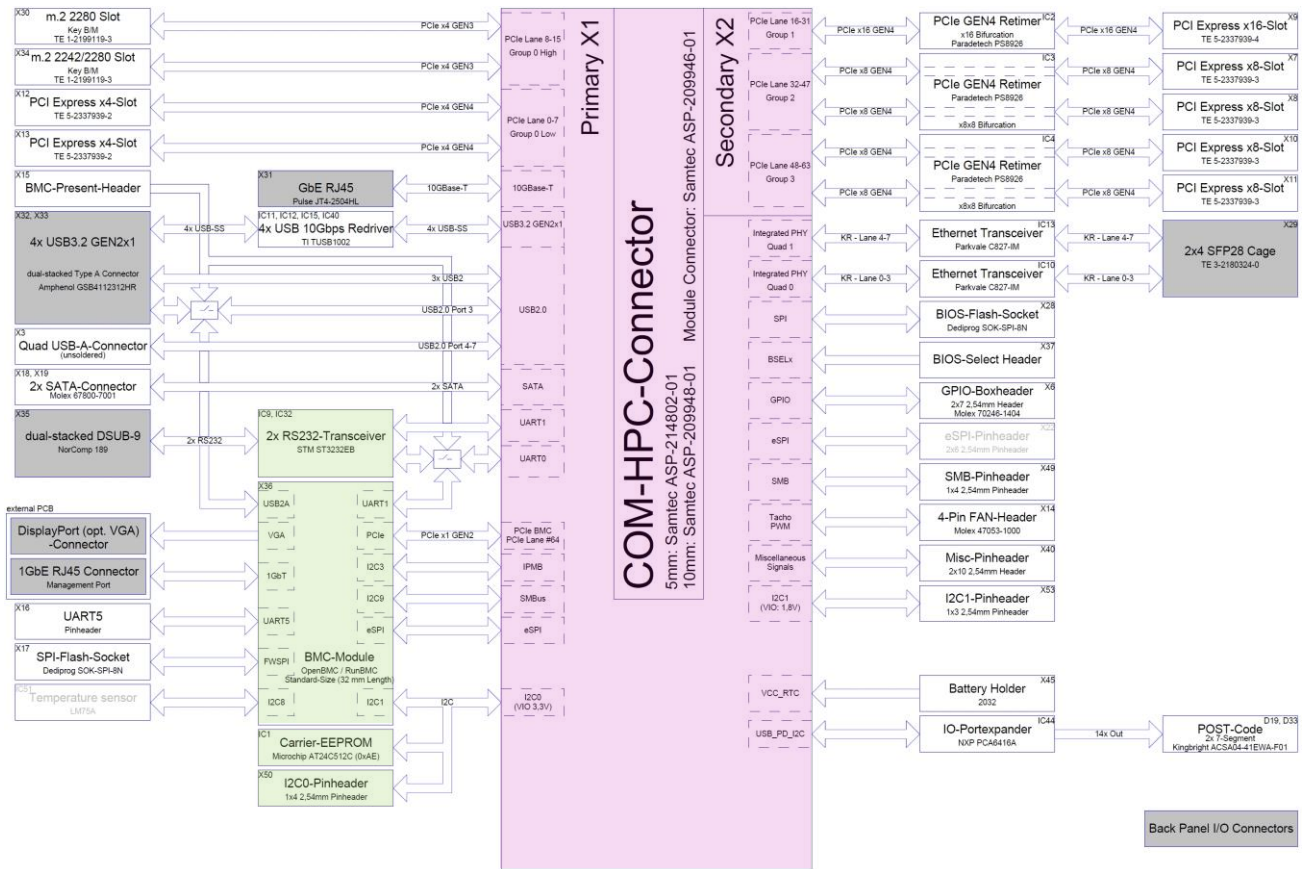

3/ Mainboard Views

3.1. Top View

Figure 3: Top View of COM-HPC Server Evaluation Carrier

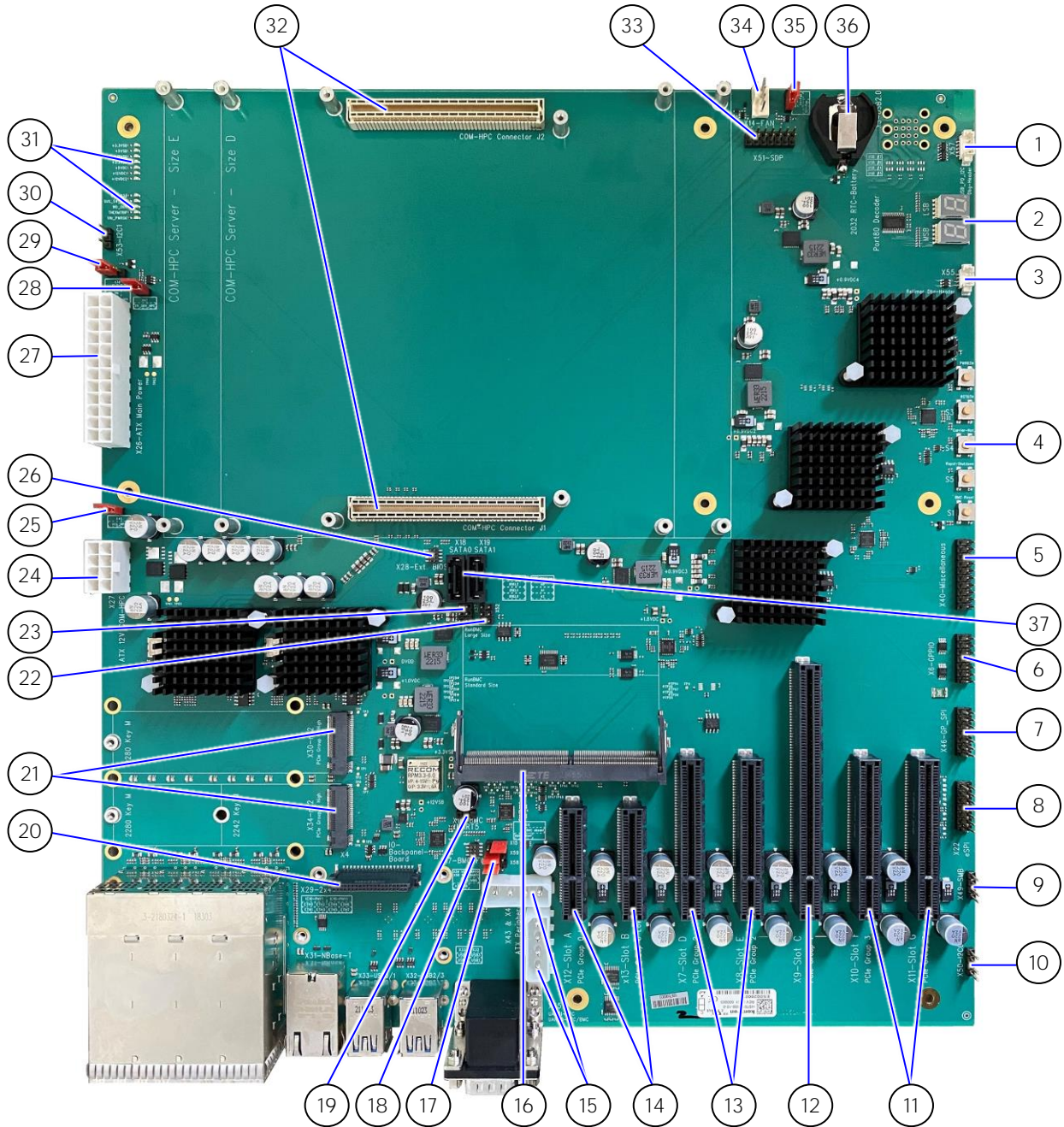

1. USB_PD_I2C Header (X57)
2. BIOS POST Code Display
3. Parade I2C Debug Board Connector (X55)
4. 5x Button Switches
5. Miscellaneous Header (X40)
6. GPIO Header (X6)
7. GP_SPI Header (X46)
8. eSPI Header (X22, not placed)
9. SMBus Header (X49)
10. I2CO Header (X50)
11. 2x PCIe x8 (X10, X11)
12. PCIe x16 (X9)
13. 2x PCIe x8 (X7, X8)
14. 2x PCIe x4 (X12, X13)
15. ATX Peripheral Connectors (X43, X44)
16. BMC Connector (X36)
17. 3x Jumpers: BMC Present (X15), UART0 VCC Selection (X59), UART1 VCC Selection (X58)
18. SPI Flash Socket (X17)
19. UART5 Pinheader (X16)
20. IO Backpanel Board Connector (X4)
21. 2x M.2 (X30, X34)
22. COM-HPC PICMG EEPROM (X52)
23. BIOS Select Jumper (X37)
24. ATX +12V Power Connector 8 Pin (X27)
25. Enable VCC_HPC Jumper (X48)
26. BIOS Flash Socket (X28)
27. ATX Main Power Connector 24 pins (X26)
28. 5V_Standby_HPC Jumper (X47)
29. Manual PS_ON or by SUS_S3, Jumper (X39)
30. I2C1 Header (X53)
31. Status LEDs and Power LEDs
32. 2x COM-HPC Connectors (J1, J2)
33. SDP Header (X51)
34. Fan Connector (X14)
35. 5V/12V Fan Jumper (X38)
36. RTC Battery CR2032 Socket (X45)
37. 2x SATA Header (X18, X19)

3.2. Front panel

Figure 4: Front Panel

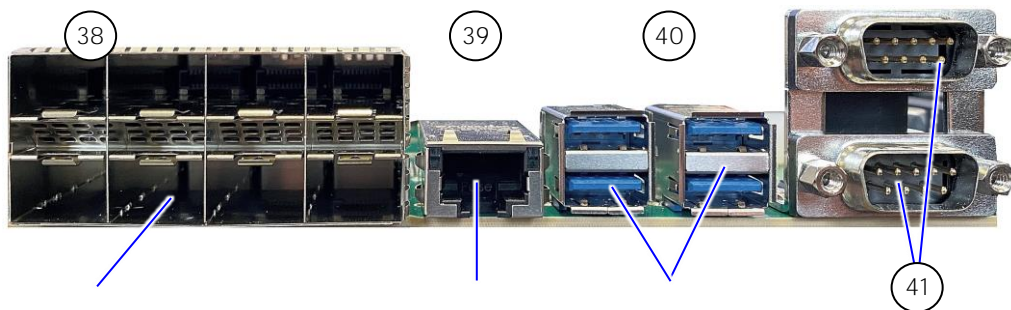

38. 8x SFP28 cages (X29)
39. 1x RJ45 (X31)
40. 4x USB (X32, X33)
41. 2x COM (X35)

4/ Mechanical Specification

4.1. Dimensions and Jumper Positions

The dimensions of the carrier board are 330 mm x 305 mm.

Figure 5: Board Dimensions and Jumper Positions

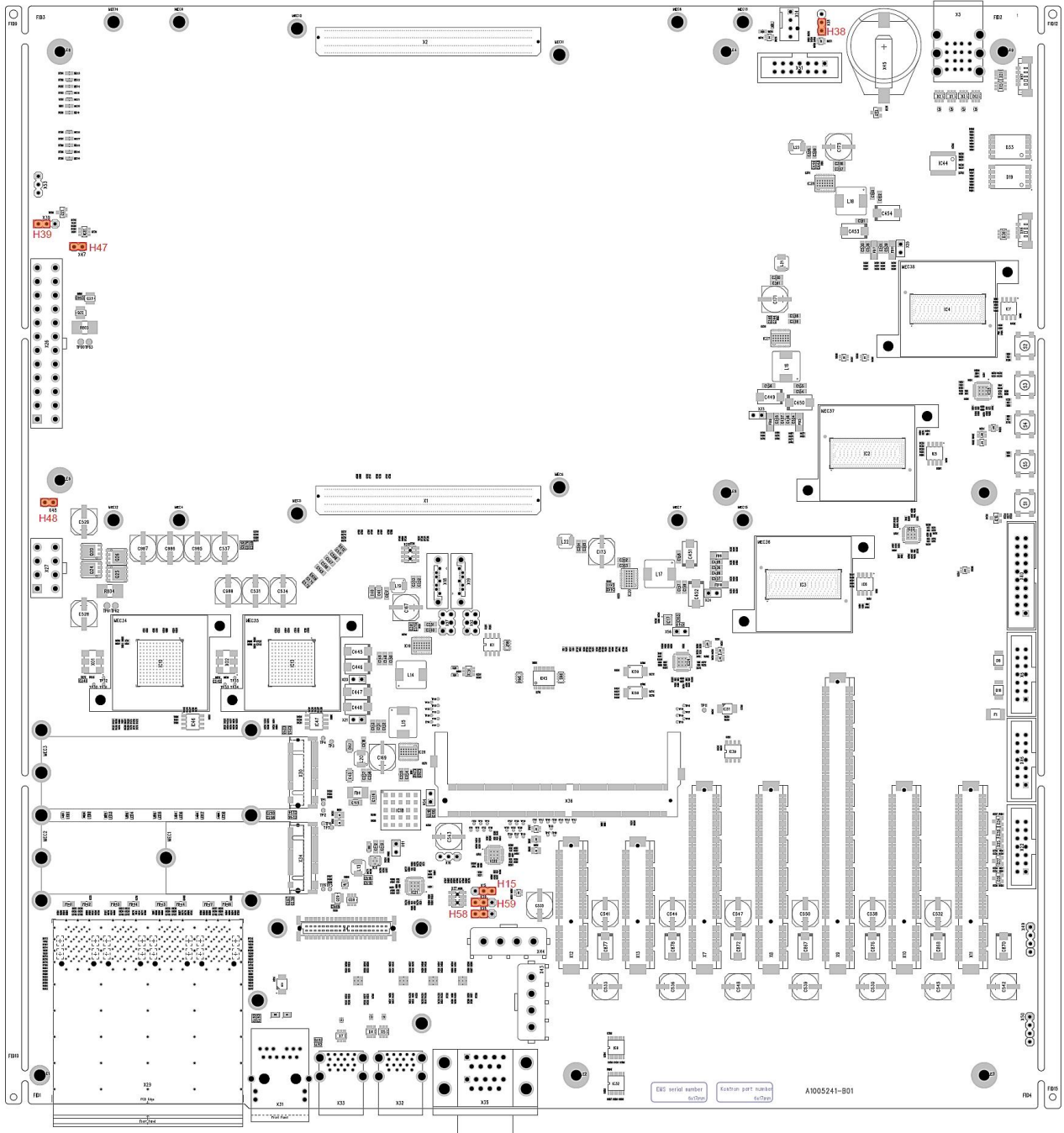

5/ Interfaces and Connectors

5.1. IO Backpanel Board Connector (X4)

Figure 6: IO Backpanel Board Connector

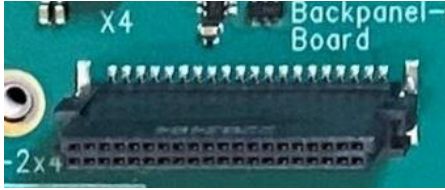

Table 3: IO Backpanel Board Connector

Signal Name	Pin	Pin	Signal Name
+5VDC	1	21	+5VDC
+5VDC	2	22	+5VDC
GND	3	23	GND
GND	4	24	BMC_DACG_DPTXPO
BMC_VGAHS_DPTXP1	5	25	BMC_DACB_DPTXNO
BMC_VGAVS_DPTXN1	6	26	GND
GND	7	27	BMC_DDCCLK_DPAUXP
GND	8	28	BMC_DDCDAT_DPAUXN
GND	9	29	GND
BMC_DACR_DPHPD	10	30	BMC_PHYLED1
BMC_PHYLED2	11	31	BMC_PHYLED3
GND	12	32	GND
+3.3VSB	13	33	+3.3VSB
+3.3VSB	14	34	+3.3VSB
GND	15	35	GND
BMC_TRD3	16	36	BMC_TRD2N
BMC_TRD3P	17	37	BMC_TRD2P
GND	18	38	GND
BMC_TRD1N	19	39	BMC_TRDON
BMC_TRD1P	20	40	BMC_TRDOP
NC	M1	M3	NC
NC	M2	M4	NC

5.2. Up to 10 GB Ethernet Connector (X31)

Table 4: Max 10 GB Ethernet Connector

Pin	Signal	10 BASE-T 100BASE-T	Max 10GBASE-T
1	MDIO+	TX+	DA+
2	MDIO-	TX-	DA-
3	MDI1+	RX+	DB+
4	MDI2+		DC+
5	MDI2-		DC-
6	MDI1-	RX-	DB-
7	MDI3+		DD+
8	MDI3-		DD-

Table 5: Signals

LED	Signal
1	Green (right): Link/Activity
2	Green (left): Link Max
2	Yellow (left): Link Mid

5.3. USB 3.2 Double Connector (X32, X33)

Figure 7: USB 3.2 Double Connector (X32, X33)



Table 6: USB 3.2 Double Connector Pinout (X32, X33)

Pin	Signal Name – X33 (left)		Signal Name – X32 (right)	
1	VBUS0	BOTTOM SLOT	VBUS0	BOTTOM SLOT
2	D0-		D0-	
3	D0+		D0+	
4	GND0		GND0	
5	SSRX0-		SSRX0-	
6	SSRX0+		SSRX0+	
7	GND_DRAIN0		GND_DRAIN0	
8	SSTX0-		SSTX0-	
9	SSTX0+		SSTX0+	
10	VBUS1		TOP SLOT	

Pin	Signal Name – X33 (left)	Signal Name – X32 (right)
11	D1-	D1-
12	D1+	D1+
13	GND1	GND1
14	SSRX1-	SSRX1-
15	SSRX1+	SSRX1+
16	GND_DRAIN1	GND_DRAIN1
17	SSTX1-	SSTX1-
18	SSTX1+	SSTX1+
SH1	GND	GND
SH2	GND	GND
SH3	GND	GND
SH4	GND	GND

5.4. COM Ports (X35)

Figure 8: Double COM Ports



Table 7: Double COM Ports

Pin	Signal Name	
A1	NC	BOTTOM SLOT
A2	RS232-0_RX	
A3	RS232-0_TX	
A4	NC	
A5	GND	
A6	NC	
A7	RS232-0_RTS#	
A8	RS232-0_CTS#	
B1	NC	TOP SLOT
B2	RS232-1_RX	
B3	RS232-1_TX	
B4	NC	
B5	GND	
B6	NC	
B7	RS232-1_RTS#	

Pin	Signal Name	
B8	RS232-1_CTS#	
B9	NC	

5.5. BMC Connector (X36)

Figure 9: BMC Connector (X36)

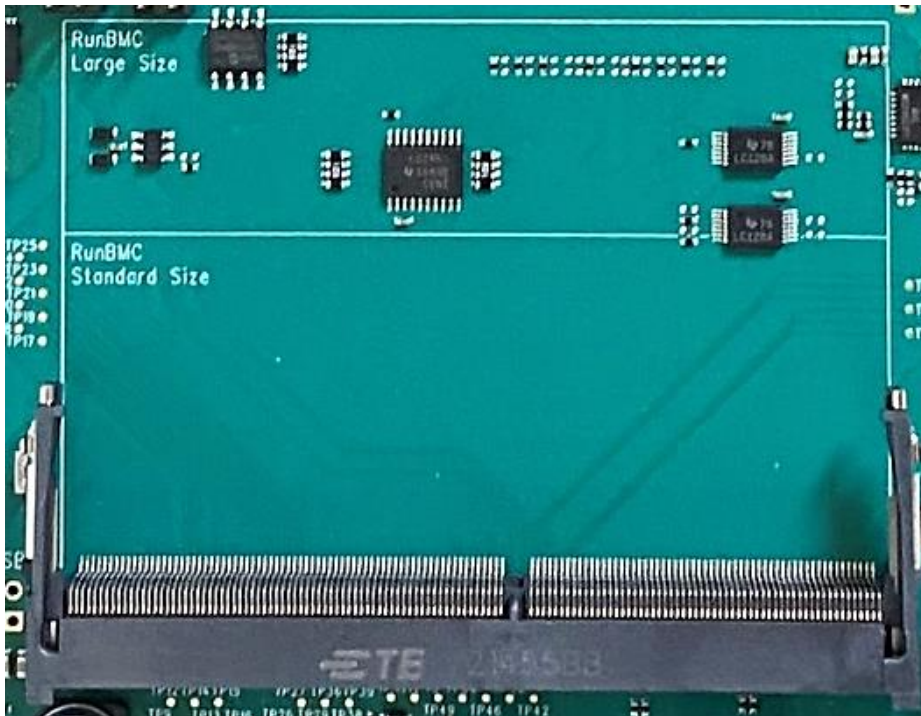

Table 8: BMC Connector (X36)

Signal Name	Pin	Pin	Signal Name
+12V SB	1	2	NC
+3.3V SB	3	4	+3.3V SB
+3.3V SB	5	6	+3.3V SB
+3.3V SB	7	8	GND
GND	9	10	BMC_DACG_DPTXP0
GND	11	12	BMC_DACB_DPTXN0
TP9	13	14	BMC_DACR_DPHPD
TP10	15	16	BMC_VGAHS_DPTXP1
TP12	17	18	BMC_VGAVS_DPTXN1
TP13	19	20	BMC_DDCCLK_DPAUXP
BMC_UART5_RX	21	22	BMC_DDCDAT_DPAUXN
BMC_UART5_TX	23	24	GND
TP14	25	26	NC
NC	27	28	NC
NC	29	30	NC
NC	31	32	NC
GND	33	34	NC
TP15	35	36	TP17

Signal Name	Pin	Pin	Signal Name
TP16	37	38	TP18
GND	39	40	NC
BMC_UART1_RX	41	42	NC
BMC_UART1_TX	43	44	NC
GND	45	46	TP19
BMC_I2C8_SCL	47	48	NC
BMC_I2C8_SDA	49	50	NC
GND	51	52	GND
NC	53	54	NC
NC	55	56	NC
GND	57	58	GND
BMC_FWSPWP#	59	60	NC
NC	61	62	NC
BMC_FWSPICSO#	63	64	GND
BMC_FWSPIMOSI_I00	65	66	TP20
BMC_FWSPIMISO_I01	67	68	TP21
BMC_FWSP_I02	69	70	TP22
BMC_FWSP_I03	71	72	TP23
BMC_FWSPICK	73	74	TP24
NC	75	76	TP25
BMC_PWRGD	77	78	NC
TP26	79	80	NC
TP27	81	82	NC
TP28	83	84	NC
TP29	85	86	NC
TP36	87	88	NC
TP37	89	90	NC
TP38	91	92	NC
TP39	93	94	NC
TP40	95	96	NC
PLTRST6#	97	98	NC
TP41	99	100	NC
TP42	101	102	NC
TP43	103	104	NC
TP44	105	106	NC
TP45	107	108	NC
TP46	109	110	GND
NC	111	112	NC
TP47	113	114	GND
TP48	115	116	NC
TP49	117	118	NC
TP50	119	120	NC

Signal Name	Pin	Pin	Signal Name
NC	121	122	NC
NC	123	124	NC
NC	125	126	GND
GND	127	128	BMC_I2C1_SCL
NC	129	130	BMC_I2C1_SDA
NC	131	132	GND
GND	133	134	BMC_I2C4_SCL
NC	135	136	BMC_I2C4_SDA
NC	137	138	TP51
GND	139	140	TP52
NC	141	142	BMC_PERST#
NC	143	144	TP53
GND	145	146	TP54
COMH_PEBMC_TN	147	148	TP56
COMH_PEBMC_TP	149	150	TP57
GND	151	152	+1.8VDC
COMH_PEBMC_RN	153	154	TP58
COMH_PEBMC_RP	155	156	TP59
GND	157	158	TP55
REFCLKOL_3N	159	160	NC
REFCLKOL_3P	161	162	NC
GND	163	164	NC
BMC_ESPIRST#	165	166	NC
BMC_ESPID1	167	168	NC
BMC_ESPID0	169	170	NC
BMC_ESPIALERT#	171	172	NC
BMC_ESPICS#	173	174	NC
BMC_ESPID3	175	176	NC
BMC_ESPID2	177	178	NC
BMC_ESPICK	179	180	NC
BMC_I2C9_SCL	181	182	NC
BMC_I2C9_SDA	183	184	NC
GND	185	186	NC
NC	187	188	NC
NC	189	190	NC
GND	191	192	NC
NC	193	194	NC
NC	195	196	NC
GND	197	198	NC
NC	199	200	NC
NC	201	202	NC
GND	203	204	NC

Signal Name	Pin	Pin	Signal Name
BMC_I2C3_SCL	205	206	NC
BMC_I2C3_SDA	207	208	NC
NC	209	210	NC
NC	211	212	GND
NC	213	214	NC
GND	215	216	NC
BMC_USB2AN	217	218	NC
BMC_USB2AP	219	220	NC
GND	221	222	NC
NC	223	224	NC
NC	225	226	GND
GND	227	228	NC
BMC_TRD0P	229	230	NC
BMC_TRD0N	231	232	GND
GND	233	234	NC
BMC_TRD1N	235	236	NC
BMC_TRD1P	237	238	GND
GND	239	240	BMC_PHYLED1
BMC_TRD2P	241	242	BMC_PHYLED2
BMC_TRD2N	243	244	BMC_PHYLED3
GND	245	246	NC
BMC_TRD3N	247	248	NC
BMC_TRD3P	249	250	NC
GND	251	252	NC
BMC_RESET#	253	254	NC
NC	255	256	NC
NC	257	258	NC
NC	259	260	NC

5.6. SATA 6 GB (X18, X19)

Figure 10: SATA 6 GB



Table 9: SATA 6 GB Connector

Pin	Signal Name – X18	Signal Name – X19
1	GND_0	GND_0
2	SATA0_TX+	SATA1_TX+
3	SATA0_TX-	SATA1_TX-
4	GND_1	GND_1
5	SATA0_RX-	SATA1_RX-
6	SATA0_RX+	SATA1_RX+
7	GND_2	GND_2
8	GND (MEC_0)	GND (MEC_0)
9	GND (MEC_1)	GND (MEC_1)

5.7. PCIe Slots (X7 – X13)

Table 10: PCIe Slots

PCIe Slot	Connector	PCIe Lanes
PCIe A x16	X9	16 lanes PCIe[16..31]
PCIe B x8	X7	8 lanes PCIe[32..39]
PCIe B x8	X8	8 lanes PCIe[40..47]
PCIe B x8	X10	8 lanes PCIe[48..55]
PCIe B x8	X11	8 lanes PCIe[56..63]
PCIe C x4	X12	4 lanes PCIe[4..7]
PCIe D x4	X13	4 lanes PCIe[0..3]

Figure 11: PCIe x4 Slots



Figure 12: PCIe x16 and PCIe x8 Slots

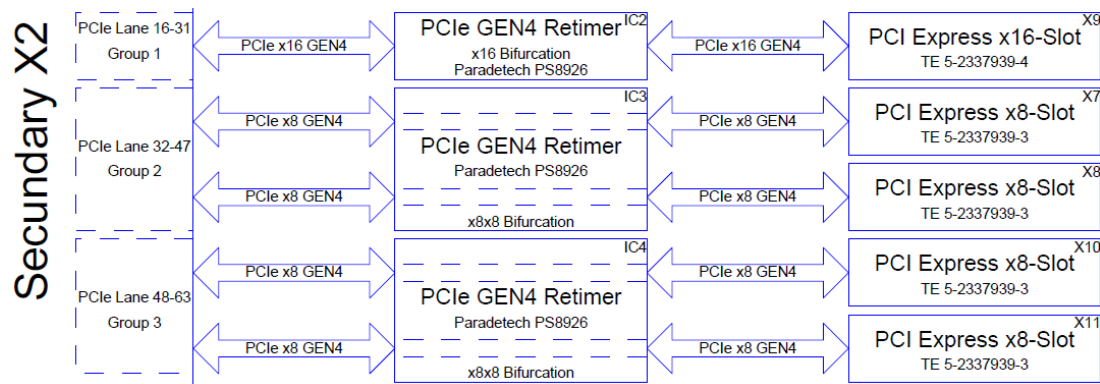

5.8. Fan Connector (X14) and Jumper (X38)

Figure 13: Fan Connector with 4 pins (X14) and Fan Jumper (X38)



5.8.1. Fan Connector with 4 Pins (X14)

Table 11: Fan Connector (X14)

Pin	Description
1	GND
2	VCC
3	TACHO
4	PWM

5.8.2. Jumper for 5V/12V Fan Selection (X38)

Table 12: Jumper for 5V/12V Fan Selection

Jumper Position	Description
1-2	12V Fan (default)
2-3	5V Fan

5.9. UART0 BMC Present Header (X15)

Figure 14: BMC Present Jumper (X15) with 3 pins



Table 13: BMC Present Jumper (X15)

Jumper Position	Description
1-2	BMC present
2-3	BMC absent (default)

5.10. UART – VCC Selection Jumpers (X58, X59)

Figure 15: UART – VCC Selection Jumpers (X58, X59) with 3 pins



Table 14: VCC Selection Jumpers (X58, X59)

Pin	X58 (UART1)	X59 (UART0)
1	+3.3VDC	+3.3VDC
2	VCC_UART1	VCC_UART0
3	+3.3VSB	+3.3VSB

Jumper Position	Description
1-2	+3.3VDC source for VCC_UART0/1
2-3	+3.3VSB source for VCC_UART0/1 (default)

5.11. UART5 Header (X16)

Applicable when RunBMC module is plugged

Figure 16: UART5 Header (X16)



Table 15: UART5 Header (X16)

Pin	Description
1	BMC_UART5_TX
2	GND
3	BMC_UART5_RX

5.12. FW SPI Flash Socket for BMC (X17)

Figure 17: SPI Flash Socket for BMC



Table 16: SPI Flash Socket for BMC

Signal Name	Pin	Pin	Signal Name
CS#	1	2	VCC
MISO	3	4	HOLD#
WP#	5	6	CLK
GND	7	8	MOSI

5.13. BIOS Flash Socket (X28)

Figure 18: BIOS Flash Socket (X28)



Table 17: BIOS Flash Socket (X28)

Signal Name	Pin	Pin	Signal Name
CS#	1	2	VCC
MISO	3	4	HOLD#
WP#	5	6	CLK
GND	7	8	MOSI

5.14. BIOS Select Jumper (X37)

Figure 19: BIOS Select Jumper (X37)

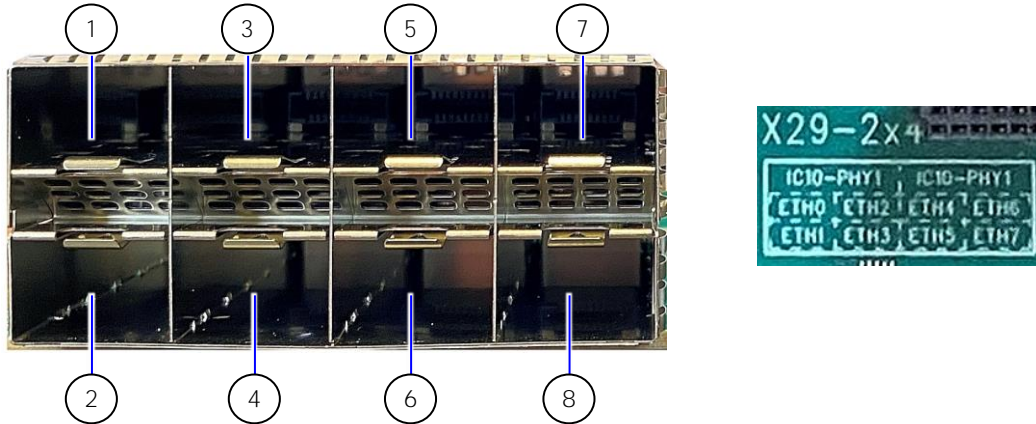

Table 18: BIOS Select Jumper (X37)

Jumper Position	Description
5-6 (Top)	BSEL2 (Select BIOS 2)
3-4 (Middle)	BSEL1 (Select BIOS 1)
1-2 (Bottom)	BSEL0 (Select BIOS 0)

5.15. 2x4 SFP28 Cage (X29)

Figure 20: Side View of 2x4 SFP28 Cage (X29)



- | | | | |
|---|------|---|------|
| 1 | ETH0 | 5 | ETH4 |
| 2 | ETH1 | 6 | ETH5 |
| 3 | ETH2 | 7 | ETH6 |
| 4 | ETH3 | 8 | ETH7 |

Figure 21: 2x4 SFP28 Cage (X29) - Block Diagram (Detail)

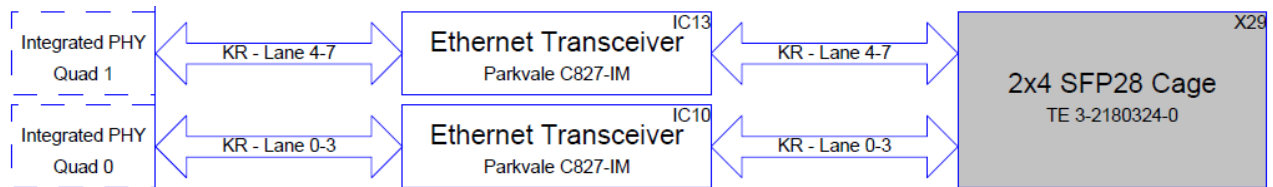

5.16. GPIO - General Purpose Input and Output (X6)

The COM-HPC Client Evaluation Carrier offers 14 pins.

Figure 22: GPIO Header (X6)



Table 19: GPIO Header (X6)

Signal Name	Pin	Pin	Signal Name
+3.3VDC	1	2	COMH_GPIO06
COMH_GPIO00	3	4	COMH_GPIO07
COMH_GPIO01	5	6	COMH_GPIO08
COMH_GPIO02	7	8	COMH_GPIO09
COMH_GPIO03	9	10	COMH_GPIO10
COMH_GPIO04	11	12	COMH_GPIO11
COMH_GPIO05	13	14	GND

5.17. Miscellaneous Header (X40)

Figure 23: Miscellaneous Header (X40)



Table 20: Miscellaneous Header (X40)

Signal Name	Pin	Pin	Signal Name
COMH_PWRBTN#	1	2	THERMTRIP#
COMH_RSTBTN#	3	4	COMH_CARRIER_HOT#
PLTRST2#	5	6	COMH_RAPID_SHUTDOWN
COMH_VIN_PWROK	7	8	COMH_SUS_S3#
COMH_BATLOW#	9	10	SUS_S4_S5#
WD_OUT	11	12	COMH_WAKE0#
COMH_WD_STROBE#	13	14	COMH_WAKE1#
COMH_TAMPER#	15	16	COMH_TYPE1
COMH_TEST#	17	18	COMH_TYPE2
COMH_TYPE0	19	20	GND

5.18. GP_SPI Header (X46)

Figure 24: GP_SPI Header (X46)



Table 21: GP_SPI Header (X46)

Signal Name	Pin	Pin	Signal Name
+3.3VSB	1	2	COMH_SPI_CS2#
COMH_SPI_MOSI	3	4	COMH_SPI_CS3#
COMH_SPI_MISO	5	6	COMH_GP_SPI_CLK
COMH_SPI_CS0#	7	8	COMH_GP_SPI_ALERT#
COMH_SPI_CS1#	9	10	NC
NC	11	12	NC
NC	13	14	GND

5.19. SUS_S3# / PS_ON Jumper (X39)

Figure 25: SUS_S3# / PS_ON Jumper (X39)



Table 22: SUS_S3# / PS_ON Jumper (X39)

Jumper Position	Description
1-2	PSON by SUS_S3# (ATX-Mode)
2-3	Manual PSON (AT-Mode, default)

5.20. Enable 5V_SBY_HPC Jumper (X47)

Figure 26: Enable 5V_SBY_HPC Jumper (X47)



Table 23: Enable 5V_SBY_HPC Jumper (X47)

Jumper Position	Description
1-2	Enable 5V_SBY_HPC

5.21. Enable VCC_HPC Jumper (X48)

Figure 27: Enable VCC_HPC Jumper (X48)



Table 24: Enable VCC_HPC Jumper (X48)

Jumper Position	Description
1-2	Enable VCC_HPC

5.22. I2C0 Header (X50)

The I2C Interface supports clock from 127Hz to 400kHz (limited by on board devices and capacitive loading) and can be configured in Setup.

Figure 28: I2C0 Header, 4-pin (X50)



Table 25: I2C0 Header (X50)

Pin	Description
1	COMH_I2C0_DAT
2	COMH_I2C0_CLK
3	COMH_I2C0_ALERT#
4	GND

5.23. I2C1 Header (X53)

The I2C Interface supports clock from 127Hz to 400kHz (limited by on board devices and capacitive loading) and can be configured in Setup.

Figure 29: I2C1 Header, 3-pin (X53)



Table 26: I2C1 Header (X53)

Pin	Description
1	COMH_I2C1_DAT
2	COMH_I2C1_CLK

Pin	Description
3	GND

5.24. SMBus Header (X49)

Figure 30: SMBus Header (X49)



Table 27: SMBus Header (X49)

Pin	Description
1	COMH_SMB_DAT
2	COMH_SMB_CLK
3	COMH_SMB_ALERT#
4	GND

5.25. SDP Header (X51)

Figure 31: SDP Header (X51)



Table 28: SDP Header (X51)

Signal Name	Pin	Pin	Signal Name
NC	1	2	NC
NC	3	4	NC
COMH_ETH0_SDP	5	6	COMH_ETH1_SDP
COMH_ETH2_SDP	7	8	COMH_ETH3_SDP
COMH_ETH4_SDP	9	10	COMH_ETH5_SDP
COMH_ETH6_SDP	11	12	COMH_ETH7_SDP
COMH_NBASET_SDP	13	14	GND

5.26. COM-HPC PICMG EEPROM Header (X52)

Figure 32: COM-HPC PICMG EEPROM Header (X52)

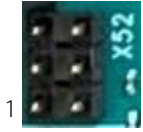

Table 29: SDP Header (X52)

Signal Name	Pin	Pin	Signal Name
GND	1	2	A2
GND	3	4	A1
GND	5	6	A0

5.27. Parade I2C Debug Board Header (X55)

Figure 33: Parade I2C Debug Board Header (X55)



Table 30: Parade I2C Debug Board Header (X55)

Pin	Description
1	SMCLK_RETIMER
2	SMDAT_RETIMER
3	GND
4	+3.3VDC

5.28. USB_PD_I2C Header (X57)

Figure 34: USB_PD_I2C Header (X57)



Table 31: USB_PD_I2C Header (X57)

Pin	Description
1	+3.3VSB
2	COMH_USB_PD_I2C_CLK
3	COMH_USB_PD_I2C_DAT
4	PLTRST3#
5	GND

5.29. ATX Main Power Connector (X26)

Figure 35: ATX Main Power Connector (X26)

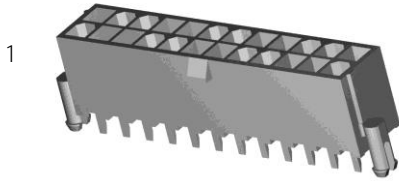

Table 32: ATX Main Power Connector with 24 pins (X26)

Signal Name	Pin	Cable Colour	Signal Name	Pin	Cable Colour
+3.3VDC	1	Orange	+3.3VDC	13	Orange
+3.3VDC	2	Orange	NC	14	Blue
GND	3	Black	GND	15	Black
+5VDC	4	Red	PSON_ATX#	16	Green
GND	5	Black	GND	17	Black
+5VDC	6	Red	GND	18	Black
GND	7	Black	GND	19	Black
PWR_OK	8	Grey	NC	20	White
5VSB	9	Purple	+5VDC	21	Red
+12VDC1	10	Yellow	+5VDC	22	Red
+12VDC1	11	Yellow	+5VDC	23	Red
+3.3VDC	12	Orange	GND	24	Black

5.30. ATX Power Connector (X27)

Figure 36: ATX Power connector with 8 pins (X27)

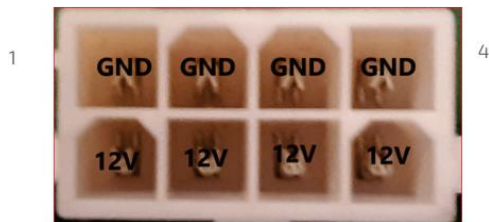

Table 33: ATX Power connector with 8 pins (X27)

Signal Name	Pin	Pin	Signal Name
GND	1	5	+12VDC2
GND	2	6	+12VDC2
GND	3	7	+12VDC2
GND	4	8	+12VDC2

5.31. RTC Battery Socket (X45)

Figure 37: RTC Battery Socket

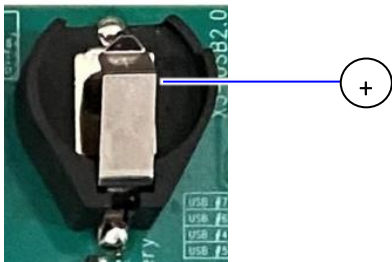

Table 34: RTC Socket

Pin	Signal Name
1	COMH_VCC_RTC (+)
2	GND (-)

5.32. Button Switches (S1 – S5)

Figure 38: Button Switches

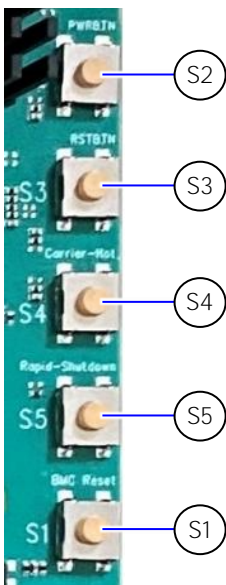

Table 35: Control Buttons

Button Switch	Function
S1	BMC Reset Button
S2	Power Button
S3	Reset Button
S4	Carrier_Hot Button
S5	Rapid Shutdown

NOTICE

Rapid shutdown requires disconnecting V_WIDE_S0_MOD and V_5V0_S5_MOD rails externally.

5.33. M.2 Key-M Socket (X30, X34)

X30 = M.2 Key M 2280 slot

X34 = M.2 Key M 2242/2280 slot

Figure 39: M.2 Slot Connector (X30, X34)

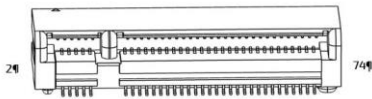

Table 36: Pin Assignment M.2 Connector

Signal Name	Pin	Pin	Signal Name
V3.3-1	2	1	CFG3
V3.3-2	4	3	GND
NC	6	5	PETN3/NC
NC	8	7	PETP3/NC
DAS/DSS	10	9	GND
V3.3-3/KEYB	12	11	PERN3/NC
V3.3-4/KEYB	14	13	PERP3/KEYB
V3.3-5/KEYB	16	15	GND/KEYB
V3.3-6/KEYB	18	17	PETN2/KEYB
NC	20	19	PETP2/KEYB
NC	22	21	CFG0
NC	24	23	PERN2/NC
NC	26	25	PERP2/NC
NC	28	27	GND
NC	30	29	PETN1/NC
NC	32	31	PETP1/NC
NC	34	33	GND
NC	36	35	PERN1/NC
DEVSLP	38	37	PERP1/NC
NC	40	39	GND
NC	42	41	PETN0/SATA_TP
NC	44	43	PETP0/SATA_TN
NC	46	45	GND
NC	48	47	PERN0/SATA_RN
PERST/NC	50	49	PERP0/SATA_RP
CLKREQ/NC	52	51	GND

Signal Name	Pin	Pin	Signal Name
PEWAKE/NC	54	53	REFCLKN/NC
MFG1/TWI_DAT	56	55	REFCLKP/N
MFG2/TWI_CLK	58	57	GND
Key M Area			
SUSCLK	68	67	NC
V3.3-7	70	69	PEDET/CFG1
V3.3-8	72	71	GND
V3.3-9	74	73	GND
		75	CFG2

6/ Electrical Specification

Supply Voltage

- ▶ 1x ATX main power 24-pin
- ▶ 1x ATX power 8-pin
- ▶ 2x ATX peripheral power

6.1. Power Supply Rise time

- ▶ The input voltages shall rise from $\leq 10\%$ of nominal to within the regulation ranges within 0.1ms to 20ms.
- ▶ There must be a smooth and continuous ramp of each DC input voltage from 10% to 90% of its final set-point following the ATX specification

NOTICE

If any of the supply voltages drops below the allowed operating level longer than the specified hold-up time, all the supply voltages should be shut down and left OFF for a time long enough to allow the internal board voltages to discharge sufficiently. If the OFF time is not observed, parts of the board or attached peripherals may work incorrectly or even suffer a reduction of MTBF. The minimum OFF time depends on the implemented PSU model and other electrical factors and needs to be measured individually for each case.

6.2. Supply Voltage Tolerances

- ▶ Supply voltage has to comply with ATX specification

NOTICE

To protect external power lines of peripheral devices, make sure that the wires have the right diameter to withstand the maximum available current. The enclosure of the peripheral device has to fulfill the fire-protection requirements of IEC/EN62368.

Figure 40: Power Diagram

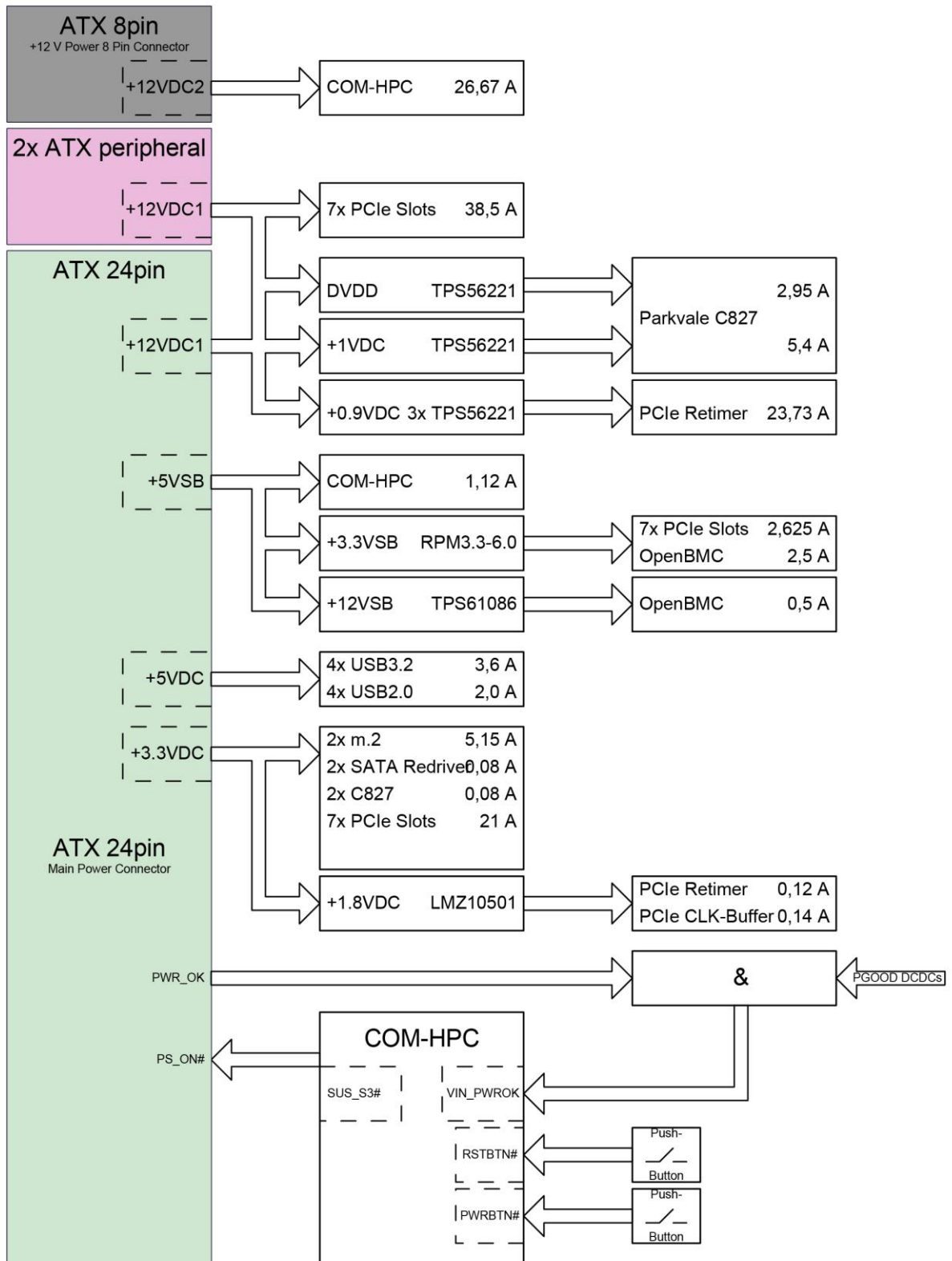

7/ Features

7.1. Rapid Shutdown Button (SW5)







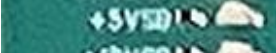

The rapid shutdown button (SW5) has currently no function.

7.2. LEDs and Indicators

Indicators and LEDs indicate only presence of voltage on certain signal, but not necessarily a correct shape and level of the voltage. This is important especially for power supplies – power good signal would provide more accurate indication, but it is not possible to provide this for all signals (for example ATX power signals share one power good).

7.2.1. Power and Control LEDs

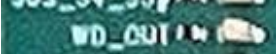
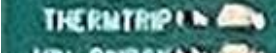
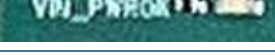
Table 37: Power and Control LEDs

	LED	Function
	23	+3.3VSB
	22	+5VSB
	24	+12VSB
	18	+3.3VDC
	21	+5VDC
	20	+12VDC1
	19	+12VDC2
	28	SUS_S3_LED#
	27	SUS_S4_S5_LED#
	25	WD_OUT_LED
	26	THERMTRIP_LED#
	29	VIN_PWROK_LED

7.2.2. SFP28 LEDs

Figure 41: SFP28 LEDs

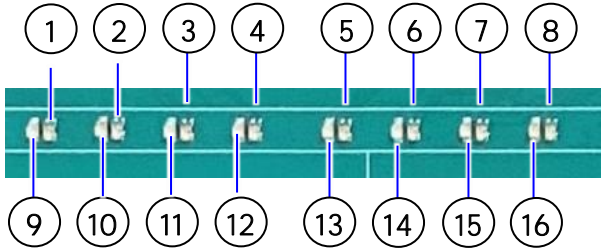

Table 38: FP28 LEDs

ETH	Function	LED	LED	Function
ETH0	LED0_LINK_ACT#	9	1	LED0_SPD_A# (green) LED0_SPD_B# (orange)
ETH1	LED1_LINK_ACT#	10	2	LED1_SPD_A# (green) LED1_SPD_B# (orange)
ETH2	LED2_LINK_ACT#	11	3	LED2_SPD_A# (green) LED2_SPD_B# (orange)
ETH3	LED3_LINK_ACT#	12	4	LED3_SPD_A# (green) LED3_SPD_B# (orange)
ETH4	LED4_LINK_ACT#	13	5	LED4_SPD_A# (green) LED4_SPD_B# (orange)
ETH5	LED5_LINK_ACT#	14	6	LED5_SPD_A# (green) LED5_SPD_B# (orange)
ETH6	LED6_LINK_ACT#	15	7	LED6_SPD_A# (green) LED6_SPD_B# (orange)
ETH7	LED7_LINK_ACT#	16	8	LED7_SPD_A# (green) LED7_SPD_B# (orange)

SPD_A: Max-Speed

SPD_B: Less than Max-Speed

LINK_ACT#: Solid with no Traffic; blinks with Traffic

7.2.3. Port 80 BIOS Debug Code Display

COM-HPC Modules may support the export of Port 80 BIOS debug codes over a specific I2C link, the USB_PD_I2C_DAT and CLK bus, to a pair of Carrier based 7-segment displays.

Figure 42: Port 80 BIOS Debug Code 7-Segment Display



- ▶ MSB: Most Significant Bit
- ▶ LSB: Least Significant Bit

8/ COM-HPC Connector Pin-out List

Figure 43: COM-HPC Connector J1 and J2

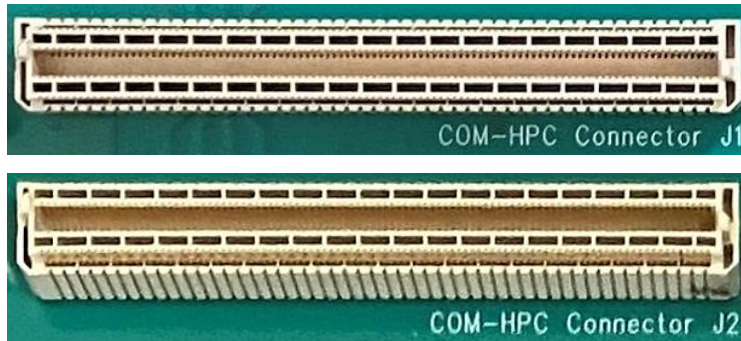

NOTICE

To protect external power lines of peripheral devices, make sure that: the wires have the right diameter to withstand the maximum available current the enclosure of the peripheral device fulfills the fire-protection requirements of IEC/EN60950.

Table 39: Pin-out List Connector J1

Pin	Row A	Row B	Row C	Row D
01	VCC	VCC	VCC	VCC
02	VCC	PWRBTN#	RSTBTN#	VCC
03	VCC	VCC	VCC	VCC
04	VCC	THERMTRIP#	CARRIER_HOT#	VCC
05	VCC	VCC	VCC	VCC
06	VCC	TAMPER#	VIN_PWR_OK	VCC
07	VCC	VCC	VCC	VCC
08	VCC	SUS_S3#	SUS_S4_S5#	VCC
09	VCC	VCC	VCC	VCC
10	GND	WD_STROBE#	GND	WAKEO#
11	BATLOW#	WD_OUT	FAN_PWMOUT	WAKE1#
12	PLTRST#	GND	FAN_TACHIN	GND
13	GND	USB5-	GND	USB1-
14	USB7-	USB5+	USB3-	USB1+
15	USB7+	GND	USB3+	GND
16	GND	USB4-	GND	USB0-
17	USB6-	USB4+	USB2-	USB0+
18	USB6+	GND	USB2+	GND
19	GND	(RSVD) *	GND	ETHO_RX-
20	ETH4_RX-	(RSVD) *	ETHO_TX-	ETHO_RX+
21	ETH4_RX+	(RSVD) *	ETHO_TX+	GND
22	GND	(RSVD) *	GND	ETH1_RX-
23	ETH5_RX-	(RSVD) *	ETH1_TX-	ETH1_RX+

Pin	Row A	Row B	Row C	Row D
24	ETH5_RX+	VCC_5V_SBY	ETH1_TX+	GND
25	GND	USB67_OC#	GND	ETH2_RX-
26	ETH6_RX-	USB45_OC#	ETH2_TX-	ETH2_RX+
27	ETH6_RX+	USB23_OC#	ETH2_TX+	GND
28	GND	USB01_OC#	GND	ETH3_RX-
29	ETH7_RX-	(SML1_CLK) *	ETH3_TX-	ETH3_RX+
30	ETH7_RX+	(SML1_DAT) *	ETH3_TX+	GND
31	GND	(PMCALERT#)*	GND	USB3_SSTX-
32	(RSVD)*	(SMLO_CLK) *	USB3_SSRX-	USB3_SSTX+
33	(RSVD)*	(SMLO_DAT) *	USB3_SSRX+	GND
34	GND	(USB_PD_ALERT#)*	GND	USB2_SSTX-
35	ETH4_TX-	USB_PD_I2C_CLK	USB2_SSRX-	USB2_SSTX+
36	ETH4_TX+	USB_PD_I2C_DAT	USB2_SSRX+	GND
37	GND	(USB_RT_ENA) *	GND	USB1_SSTX0-
38	ETH5_TX-	(USB1_LSRX) *	USB1_SSRX0-	USB1_SSTX0+
39	ETH5_TX+	(USB1_LSTX) *	USB1_SSRX0+	GND
40	GND	(USBO_LSRX) *	GND	(USB1_SSTX1-)*
41	ETH6_TX-	(USBO_LSTX) *	(USB1_SSRX1-)*	(USB1_SSTX1+)*
42	ETH6_TX+	GND	(USB1_SSRX1+)*	GND
43	GND	(USBO_AUX-)*	GND	USBO_SSTX0-
44	ETH7_TX-	(USBO_AUX+)*	USBO_SSRX0-	USBO_SSTX0+
45	ETH7_TX+	(RSVD)*	USBO_SSRX0+	GND
46	GND	(RSVD)*	GND	(USBO_SSTX1-)*
47	(USB1_AUX-)*	VCC_BOOT_SPI	(USBO_SSRX1-)*	(USBO_SSTX1+)*
48	(USB1_AUX+)*	BOOT_SPI_CS#	(USBO_SSRX1+)*	GND
49	GND	BSELO	GND	SATA0_RX-
50	eSPI_IO0	BSEL1	BOOT_SPI_IO0	SATA0_RX+
51	eSPI_IO1	BSEL2	BOOT_SPI_IO1	GND
52	eSPI_IO2	eSPI_ALERT0#	BOOT_SPI_IO2	SATA0_TX-
53	eSPI_IO3	eSPI_ALERT1#	BOOT_SPI_IO3	SATA0_TX+
54	eSPI_CLK	eSPI_CS0#	BOOT_SPI_CLK	GND
55	GND	eSPI_CS1#	GND	SATA1_RX-
56	PCIe_CLKREQ0_LO#	eSPI_RST#	PCIe_REFCLK0_HI-	SATA1_RX+
57	PCIe_CLKREQ0_HI#	GND	PCIe_REFCLK0_HI+	GND
58	GND	PCIe_BMC_RX-	GND	SATA1_TX-
59	PCIe_BMC_TX-	PCIe_BMC_RX+	PCIe_REFCLK0_LO-	SATA1_TX+
60	PCIe_BMC_TX+	GND	PCIe_REFCLK0_LO+	GND
61	GND	PCIe08_RX-	GND	PCIe00_TX-
62	PCIe08_TX-	PCIe08_RX+	PCIe00_RX-	PCIe00_TX+
63	PCIe08_TX+	GND	PCIe00_RX+	GND
64	GND	PCIe09_RX-	GND	PCIe01_TX-
65	PCIe09_TX-	PCIe09_RX+	PCIe01_RX-	PCIe01_TX+

Pin	Row A	Row B	Row C	Row D
66	PCIe09_TX+	GND	PCIe01_RX+	GND
67	GND	PCIe10_RX-	GND	PCIe02_TX-
68	PCIe10_TX-	PCIe10_RX+	PCIe02_RX-	PCIe02_TX+
69	PCIe10_TX+	GND	PCIe02_RX+	GND
70	GND	PCIe11_RX-	GND	PCIe03_TX-
71	PCIe11_TX-	PCIe11_RX+	PCIe03_RX-	PCIe03_TX+
72	PCIe11_TX+	GND	PCIe03_RX+	GND
73	GND	PCIe12_RX-	GND	PCIe04_TX-
74	PCIe12_TX-	PCIe12_RX+	PCIe04_RX-	PCIe04_TX+
75	PCIe12_TX+	GND	PCIe04_RX+	GND
76	GND	PCIe13_RX-	GND	PCIe05_TX-
77	PCIe13_TX-	PCIe13_RX+	PCIe05_RX-	PCIe05_TX+
78	PCIe13_TX+	GND	PCIe05_RX+	GND
79	GND	PCIe14_RX-	GND	PCIe06_TX-
80	PCIe14_TX-	PCIe14_RX+	PCIe06_RX-	PCIe06_TX+
81	PCIe14_TX+	GND	PCIe06_RX+	GND
82	GND	PCIe15_RX-	GND	PCIe07_TX-
83	PCIe15_TX-	PCIe15_RX+	PCIe07_RX-	PCIe07_TX+
84	PCIe15_TX+	GND	PCIe07_RX+	GND
85	GND	TEST#	GND	NBASET0_MDIO-
86	VCC_RTC	RSMRST_OUT#	SMB_CLK	NBASET0_MDIO+
87	SUS_CLK	UART1_TX	SMB_DAT	GND
88	GPIO_00	UART1_RX	SMB_ALERT#	NBASET0_MDI1-
89	GPIO_01	UART1_RTS#	UART0_TX	NBASET0_MDI1+
90	GPIO_02	UART1_CTS#	UART0_RX	GND
91	GPIO_03	IPMB_CLK	UART0_RTS#	NBASET0_MDI2-
92	GPIO_04	IPMB_DAT	UART0_CTS#	NBASET0_MDI2+
93	GPIO_05	GP_SPI_MOSI	I2C0_CLK	GND
94	GPIO_06	GP_SPI_MISO	I2C0_DAT	NBASET0_MDI3-
95	GPIO_07	GP_SPI_CS0#	I2C0_ALERT#	NBASET0_MDI3+
96	GPIO_08	GP_SPI_CS1#	I2C1_CLK	GND
97	GPIO_09	GP_SPI_CS2#	I2C1_DAT	NBASET0_LINK_MAX#
98	GPIO_10	GP_SPI_CS3#	NBASET0_SDP	NBASET0_LINK_MID#
99	GPIO_11	GP_SPI_CLK	NBASET0_CTREF	NBASET0_LINK_ACT#
100	TYPE0	GP_SPI_ALERT#	TYPE1	TYPE2

*Not connected

Table 40: Pin-out List Connector J2

Pin	Row E	Row F	Row G	Row H
1	RAPID_SHUTDOWN	ETH2_SDP	(VCC_5V_SBY)*	(RSVD)*
2	GND	ETH3_SDP	(FUSA_STATUS0)*	(RSVD)*
3	(RSVD)*	ETH4_SDP	(FUSA_STATUS1)*	(RSVD)*

Pin	Row E	Row F	Row G	Row H
4	(RSVD)*	ETH5_SDP	(FUSA_ALERT#)*	(RSVD)*
5	GND	ETH6_SDP	(FUSA_SPI_CS#)*	(RSVD)*
6	(RSVD)*	ETH7_SDP	(FUSA_SPI_CLK)*	(RSVD)*
7	(RSVD)*	ETH4-7_I2C_CLK	(FUSA_SPI_MISO)*	(RSVD)*
8	GND	ETH4-7_I2C_DAT	(FUSA_SPI_MOSI)*	(RSVD)*
9	(RSVD)*	ETH4-7_INT#	(FUSA_SPI_ALERT)*	(RSVD)*
10	(RSVD)*	ETH4-7_MDIO_CLK	(FUSA_VOLTAGE_ERR#)*	(RSVD)*
11	GND	ETH4-7_MDIO_DAT	(PROCHOT#)*	(RSVD)*
12	(RSVD)*	ETH4-7_PHY_INT#	(CATERR#)*	(RSVD)*
13	(RSVD)*	ETH4-7_PHY_RST#	(RSVD)*	(RSVD)*
14	GND	ETH4-7_PRSENT#	GND	(RSVD)*
15	(RSVD)*	(RSVD)*	(RSVD)*	(RSVD)*
16	(RSVD)*	(RSVD)	(RSVD)*	(RSVD)*
17	GND	(RSVD)*	(RSVD)*	(RSVD)*
18	(RSVD)*	(RSVD)*	(RSVD)*	(RSVD)*
19	(RSVD)*	GND	(RSVD)*	GND
20	GND	PCle32_RX-	GND	PCle40_TX-
21	PCle32_TX-	PCle32_RX+	PCle40_RX-	PCle40_TX+
22	PCle32_TX+	GND	PCle40_RX+	GND
23	GND	PCle33_RX-	GND	PCle41_TX-
24	PCle33_TX-	PCle33_RX+	PCle41_RX-	PCle41_TX+
25	PCle33_TX+	GND	PCle41_RX+	GND
26	GND	PCle34_RX-	GND	PCle42_TX-
27	PCle34_TX-	PCle34_RX+	PCle42_RX-	PCle42_TX+
28	PCle34_TX+	GND	PCle42_RX+	GND
29	GND	PCle35_RX-	GND	PCle43_TX-
30	PCle35_TX-	PCle35_RX+	PCle43_RX-	PCle43_TX+
31	PCle35_TX+	GND	PCle43_RX+	GND
32	GND	PCle36_RX-	GND	PCle44_TX-
33	PCle36_TX-	PCle36_RX+	PCle44_RX-	PCle44_TX+
34	PCle36_TX+	GND	PCle44_RX+	GND
35	GND	PCle37_RX-	GND	PCle45_TX-
36	PCle37_TX-	PCle37_RX+	PCle45_RX-	PCle45_TX+
37	PCle37_TX+	GND	PCle45_RX+	GND
38	GND	PCle38_RX-	GND	PCle46_TX-
39	PCle38_TX-	PCle38_RX+	PCle46_RX-	PCle46_TX+
40	PCle38_TX+	GND	PCle46_RX+	GND
41	GND	PCle39_RX-	GND	PCle47_TX-
42	PCle39_TX-	PCle39_RX+	PCle47_RX-	PCle47_TX+
43	PCle39_TX+	GND	PCle47_RX+	GND
44	GND	PCle16_RX-	GND	PCle24_TX-
45	PCle16_TX-	PCle16_RX+	PCle24_RX-	PCle24_TX+

Pin	Row E	Row F	Row G	Row H
46	PCle16_TX+	GND	PCle24_RX+	GND
47	GND	PCle17_RX-	GND	PCle25_TX-
48	PCle17_TX-	PCle17_RX+	PCle25_RX-	PCle25_TX+
49	PCle17_TX+	GND	PCle25_RX+	GND
50	GND	PCle18_RX-	GND	PCle26_TX-
51	PCle18_TX-	PCle18_RX+	PCle26_RX-	PCle26_TX+
52	PCle18_TX+	GND	PCle26_RX+	GND
53	GND	PCle19_RX-	GND	PCle27_TX-
54	PCle19_TX-	PCle19_RX+	PCle27_RX-	PCle27_TX+
55	PCle19_TX+	GND	PCle27_RX+	GND
56	GND	PCle20_RX-	GND	PCle28_TX-
57	PCle20_TX-	PCle20_RX+	PCle28_RX-	PCle28_TX+
58	PCle20_TX+	GND	PCle28_RX+	GND
59	GND	PCle21_RX-	GND	PCle29_TX-
60	PCle21_TX-	PCle21_RX+	PCle29_RX-	PCle29_TX+
61	PCle21_TX+	GND	PCle29_RX+	GND
62	GND	PCle22_RX-	GND	PCle30_TX-
63	PCle22_TX-	PCle22_RX+	PCle30_RX-	PCle30_TX+
64	PCle22_TX+	GND	PCle30_RX+	GND
65	GND	PCle23_RX-	GND	PCle31_TX-
66	PCle23_TX-	PCle23_RX+	PCle31_RX-	PCle31_TX+
67	PCle23_TX+	GND	PCle31_RX+	GND
68	GND	PCle48_RX-	GND	PCle56_TX-
69	PCle48_TX-	PCle48_RX+	PCle56_RX-	PCle56_TX+
70	PCle48_TX+	GND	PCle56_RX+	GND
71	GND	PCle49_RX-	GND	PCle57_TX-
72	PCle49_TX-	PCle49_RX+	PCle57_RX-	PCle57_TX+
73	PCle49_TX+	GND	PCle57_RX+	GND
74	GND	PCle50_RX-	GND	PCle58_TX-
75	PCle50_TX-	PCle50_RX+	PCle58_RX-	PCle58_TX+
76	PCle50_TX+	GND	PCle58_RX+	GND
77	GND	PCle51_RX-	GND	PCle59_TX-
78	PCle51_TX-	PCle51_RX+	PCle59_RX-	PCle59_TX+
79	PCle51_TX+	GND	PCle59_RX+	GND
80	GND	PCle52_RX-	GND	PCle60_TX-
81	PCle52_TX-	PCle52_RX+	PCle60_RX-	PCle60_TX+
82	PCle52_TX+	GND	PCle60_RX+	GND
83	GND	PCle53_RX-	GND	PCle61_TX-
84	PCle53_TX-	PCle53_RX+	PCle61_RX-	PCle61_TX+
85	PCle53_TX+	GND	PCle61_RX+	GND
86	GND	PCle54_RX-	GND	PCle62_TX-
87	PCle54_TX-	PCle54_RX+	PCle62_RX-	PCle62_TX+

Pin	Row E	Row F	Row G	Row H
88	PCIe54_TX+	GND	PCIe62_RX+	GND
89	GND	PCIe55_RX-	GND	PCIe63_TX-
90	PCIe55_TX-	PCIe55_RX+	PCIe63_RX-	PCIe63_TX+
91	PCIe55_TX+	GND	PCIe63_RX+	GND
92	GND	PCIe_REFCLK2-	GND	(PCIe_REFCLKINO-)*
93	PCIe_REFCLK1-	PCIe_REFCLK2+	PCIe_REFCLK3-	(PCIe_REFCLKINO+)*
94	PCIe_REFCLK1+	GND	PCIe_REFCLK3+	GND
95	GND	PCIe_CLKREQ3#	GND	(PCIe_REFCLKIN1-)*
96	PCIe_CLKREQ1#	ETH0-3_PRSNT#	ETH0-3_I2C_CLK	(PCIe_REFCLKIN1+)*
97	PCIe_CLKREQ2#	ETH0-3_PHY_RST#	ETH0-3_I2C_DAT	GND
98	(PCIe_CLKREQ_OUT0#)*	ETH0_SDP	ETH0-3_PHY_INT#	ETH0-3_MDIO_CLK
99	(PCIe_CLKREQ_OUT1#)*	ETH1_SDP	ETH0-3_INT#	ETH0-3_MDIO_DAT
100	(PCIe_PERST_IN0#)*	PCIe_PERST_IN1#	(PCIe_WAKE_OUT0#)*	(PCIe_WAKE_OUT1#)*

*Not connected

9/Variants

Table 41: Variants

Product Number	Carrier	Description
HST01-0000-10-0	COM-HPC/Server Eval-Car 10mm - COMh-sDID	COM-HPC/Server Eval-Carrier with 10mm Connector Height for Size D - Configured for COMh-sdID
HST01-0001-10-0	COM-HPC/Server Eval-Car 10mm - COMh-sDIL	COM-HPC/Server Eval-Carrier with 10mm Connector Height for Size D - Configured for COMh-sdIL

10/ Technical Support

For technical support contact our Support department:

E-mail: techsupport@jumptec.com

Make sure you have the following information available when you call:

- › Product ID Number (PN),
- › Serial Number (SN) Module's revision
- › Operating System and Kernel/Build version
- › Software modifications



The serial number can be found on the Type Label, located on the product's rear side.

Be ready to explain the nature of your problem to the service technician.

10.1. Warranty

Due to their limited service life, parts that by their nature are subject to a particularly high degree of wear (wearing parts) are excluded from the warranty beyond that provided by law. This applies to the CMOS battery, for example.



If there is a protection label on your product, then the warranty is lost if the product is opened.

10.2. Returning Defective Merchandise

All equipment returned to JUMPtec must have a Return of Material Authorization (RMA) number assigned exclusively by JUMPtec. JUMPtec cannot be held responsible for any loss or damage caused to the equipment received without an RMA number. The buyer accepts responsibility for all freight charges for the return of goods to JUMPtec's designated facility. JUMPtec will pay the return freight charges back to the buyer's location in the event that the equipment is repaired or replaced within the stipulated warranty period. Follow these steps before returning any product to JUMPtec.

1. Visit the RMA Information website: <https://www.jumptec.com/en/support/rma-information>
2. **Download the RMA Request sheet for JUMPtec GmbH and fill out the form. Take care to include a short detailed description of the observed problem or failure and to include the product identification Information (Name of product, Product number and Serial number). If a delivery includes more than one product, fill out the above information in the RMA Request form for each product.**
3. Send the completed RMA-Request form to the email address given at JUMPtec GmbH. JUMPtec will provide an RMA-Number.
4. The goods for repair must be packed properly for shipping, considering shock and ESD protection.



Goods returned to JUMPtec GmbH in non-proper packaging will be considered as customer caused faults and cannot be accepted as warranty repairs

5. Include the RMA-Number with the shipping paperwork and send the product to the delivery address provided in the RMA form or received from JUMPtec RMA Support.

11/List of Acronyms

ACPI	Advanced Configuration & Power Interface
ATX	Advanced Technology Extended – Industry standard PC Motherboard form factor and power supply definitions
BIOS	Basic Input Output System – firmware in a PC-AT system that is used to initialize system components before handing control over to the operating system
BMC	Baseboard Management Controller – located on Carrier for COM-HPC®, if implemented
COM-HPC	COM-HPC® - Computer-on-Module for High Performance Computing
EMC	ElectroMagnetic Compatibility
Gb	Gigabit
GbE	Gigabit Ethernet
GPIO	General Purpose Input Output
I2C	Inter Integrated Circuit – 2 wire (clock and data) signaling scheme allowing communication between integrated circuits, primarily used to read and load register values
IPMB	Intelligent Platform Management Bus
IPMI	Intelligent Platform Management Interface
M.2	A small form factor PCIe add-in card, for storage, WiFi, Cell Modems, etc. Standard is maintained by the PCI-SIG
MDIO	Management Data Input/Output, or MDIO, is a 2-wire serial bus that is used to manage PHYs or physical layer devices in media access controllers (MACs)
NC	No connect
PCIe	PCI-Express
PICMG	PCI Industrial Computer Manufacturers Group
PHY	Physical layer device, usually used in the context of a high speed serial interface such as Ethernet but may apply to others
POR	Power-On Reset
PSU	Power Supply Unit
RTC	Real Time Clock
S0	ACPI OS System State 0. Indicates fully on operating state.
S3	ACPI OS System State 3. Indicates Suspend to RAM.
S5	ACPI OS System State 5. Indicates Soft Off operating state.
SATA	Serial AT Attachment: serial-interface standard for hard disks
SFP+	Small Form Factor Pluggable – a PCB mounted cage and a transceiver Module that plugs into the cage, and accepts a copper or optical fiber wired network connection
SFP28	An enhanced version of SFP+, supporting higher speeds
SMB	System Management Bus.
USB	Universal Serial Bus
VDC	Voltage Direct Current
VSB	Voltage Standby
WEEE	Waste Electrical and Electronic Equipment



About JUMPtec

JUMPtec is a dynamic, forward-thinking innovator in technology and provides cutting-edge Computer-on-Modules based on highly reliable state-of-the-art technologies for a wide variety of industries. Customers benefit from accelerated time-to-market, lower total cost of ownership, extended product lifecycles and as a result the best possible solution for secure and innovative applications.

For more information, please visit: www.jumptec.com

JUMPtec GmbH

Brunnwiesenstrasse 16
94469 Deggendorf
Germany

info@jumptec.com
www.jumptec.com