

COMe-cAL6 (E2)

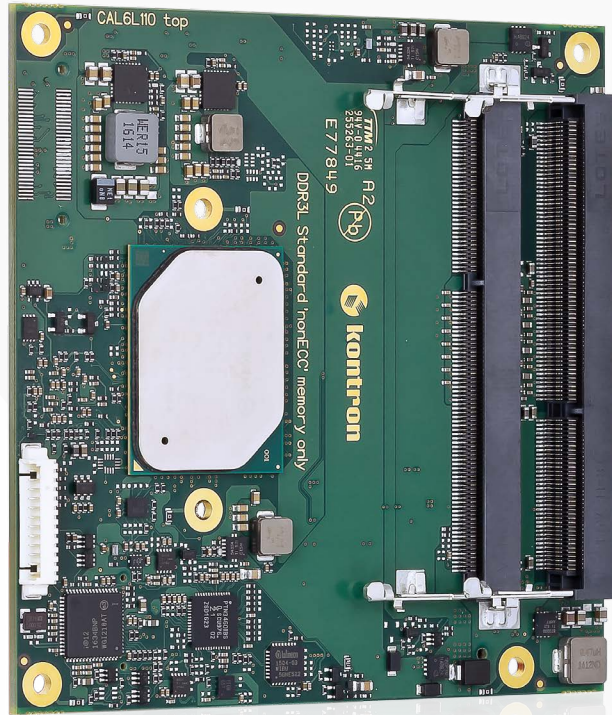

COM Express® Compact Type 6 with Intel Atom® E3900 Series, Pentium® and Celeron® Processors

- Low-power - performance/watt optimized form factor solution
- Up to 8 GByte DDR3L 1600/1866 Memory (2x SODIMM socket)
- 4x USB 3.0/2.0, 4x USB 2.0, 2x SATA, eMMC Flash
- Industrial grade temperature

COMPLIANCE	COM Express® compact, Pin-out Type 6			
DIMENSIONS	95 mm x 95 mm			
CPU	Intel Atom® E3900E Series, Pentium® and Celeron® Processor For details see table (CPU variants) given below			
CHIPSET	-			
MAIN MEMORY	2x SODIMM for DDR3L-1866 (non ECC) up to 8 GByte			
GRAPHICS CONTROLLER	Intel HD Gfx Gen9: 1x LVDS/eDP (3840 x 2160 @ 60 Hz) 2x DP (++) on DDI1/DDI2 up to 4K			
ETHERNET CONTROLLER	Intel® I210IT/I210AT (I211AT)			
ETHERNET	10/100/1000 MBit Ethernet			
STORAGE	2x SATA 6Gb/s			
FLASH ONBOARD	32 GByte eMMC SLC on request: - up to 64 GByte eMMC SLC - up to 128 GByte eMMC MLC			
PCI EXPRESS®	default on request on request	LAN yes yes no	PCIe switch no yes no	PCIe config 3x PCIe x1 5x PCIe x1 or 1x PCIe x2 + 3x PCIe x1 2x PCIe x2 or 4x PCIe x1
DISPLAY	DDI 1/2: DP++, LVDS: Dual Channel up to 48-bit or eDP (on request)			
USB	4x USB 3.0/2.0, 4x USB 2.0			
SERIAL	2x serial interface (RX/TX only)			
AUDIO	Intel® High Definition Audio			
COMMON FEATURES	SPI, LPC, SMB, Fast I ² C, Staged Watchdog, RTC			
BIOS	AMI Aptio V			
HUMIDITY	93 % relative Humidity at 40 °C, non-condensing (according to IEC 60068-2-78)			
FEATURES ON REQUEST	PCIe configurations w/ PCI hub and w/o LAN chip eMMC Flash configuration eDP instead of LVDS General Purpose SPI instead of Boot SPI USB client			
POWER MANAGEMENT	ACPI 5.0			
POWER SUPPLY	8.5 V – 20 V Wide Range, Single Supply Power			
SPECIAL FEATURES	POSCAP capacitors, Trusted Platform Module TPM 2.0, 4k Resolutions, Industrial grade temperature			
OPERATING SYSTEM	Windows® 10, Enterprise, Windows 10 IoT, Linux, VxWorks 7.x			
TEMPERATURE	COMe-cAL6 - commercial temperature: 0 °C to +60 °C operating, -30 °C to +85 °C non-operating COMe-cAL6 E2 - industrial temperature: -40 °C to +85 °C operating, -40 °C to +85 °C non-operating			

CPU Variants

BRAND	PROCESSOR NUMBER	TDP	CORES	THREADS	CACHE	BASE FREQ	MAX TURBO FREQ	GRAPHICS GEN 11	ECC	USE CONDITION
Celeron®	N3350E	6 W	2	2	2 MByte	1.1 GHz	2.4 GHz	12	no	PC Client
Pentium®	N4200E	6 W	4	4	2 MByte	1.1 GHz	2.5 GHz	18	no	PC Client
Intel Atom®	x5-E3930	6.5 W	2	2	2 MByte	1.3 GHz	1.8 GHz	12	yes	Embedded
Intel Atom®	x5-E3940	9.5 W	4	4	2 MByte	1.6 GHz	1.8 GHz	12	yes	Embedded
Intel Atom®	x7-E3950	12 W	4	4	2 MByte	1.6 GHz	2.0 GHz	18	yes	Embedded

* The COMe-cAL6 doesn't support ECC memory

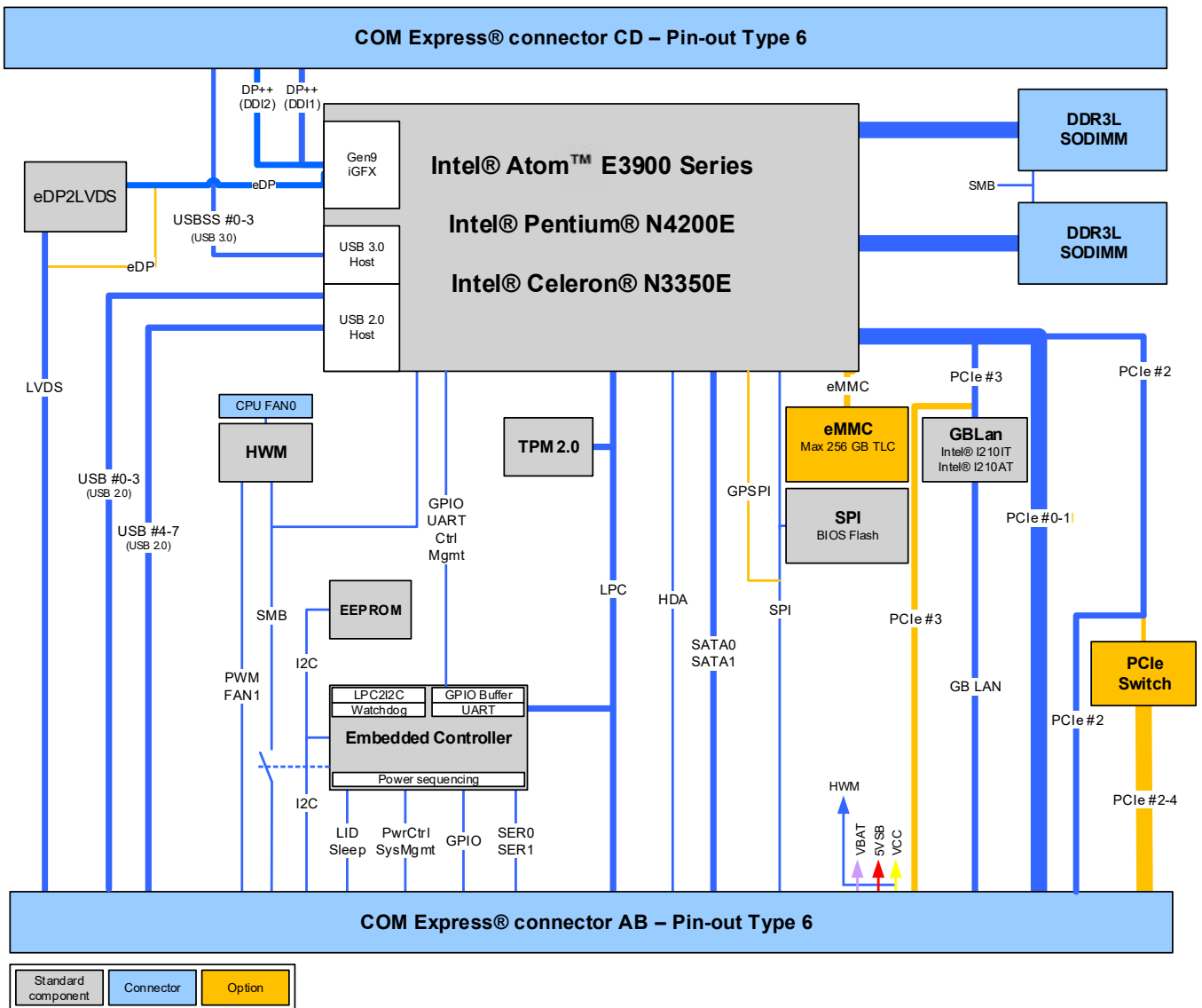

Variants

PART NO.	CPU	SO-DIMM	ETHERNET	PCIe LANES	FLASH - eMMC	VARIOUS	OP. TEMPERATURE
36023-0000-11-2	N3350E	DDR3L-1866 non ECC	I211AT	3	no	LPC, LVDS, no SecurityChip	0 °C - 60 °C
36023-0000-11-4	N4200E	DDR3L-1866 non ECC	I211AT	3	no	LPC, LVDS, no SecurityChip	0 °C - 60 °C
36024-0000-13-5	E3930	DDR3L-1866 non ECC	I210IT	3	no	LPC, LVDS, no SecurityChip	-40 °C - 85 °C
36024-0000-16-5	E3940	DDR3L-1866 non ECC	I210IT	3	no	LPC, LVDS, no SecurityChip	-40 °C - 85 °C
36024-0000-16-7	E3950	DDR3L-1866 non ECC	I210IT	3	no	LPC, LVDS, no SecurityChip	-40 °C - 85 °C
36024-0032-16-7	E3950	DDR3L-1866 non ECC	I210IT	5	32 GByte pSLC	LPC, LVDS, no SecurityChip	-40 °C - 85 °C

Please contact your sales representative for other versions.

ARTICLE	PART NO.	DESCRIPTION
COMe EVAL CARRIER2 T6	38116-0000-00-5	COM Express® Eval Carrier Type 6

Cooling

ARTICLE	PART NO.	DESCRIPTION
HSP COMe-cAL6 (E2) THREAD	36024-0000-99-0	Heatspreader for COMe-cAL6 commercial and E2, threaded mounting holes
HSP COMe-cAL6 (E2) THROUGH	36024-0000-99-1	Heatspreader for COMe-cAL6 commercial and E2, through holes
COME ACTIVE UNI COOLER (W/O HSP)	36099-0000-99-0	COM Express® Universal Active Cooler for Heatspreader Mounting (87x78x14.3 mm) (for CPU's <20 W)
COME PASSIVE UNI COOLER (W/O HSP)	36099-0000-99-1	COM Express® Universal Passive Cooler for Heatspreader Mounting (87x78x14.3 mm)
COME PASSIVE UNI COOLER2 SLIM (W/O HSP)	36099-0000-99-3	COM Express® Universal Passive Cooler low profile for Heatspreader Mounting (95x95x10 mm) 90° fin direction mounting option

Memory

PART NO.	MIN. SPEC.	SIZE	ECC	OP. TEMPERATURE
97015-4096-19-0	DDR3L-1866	4 GByte	No ECC	0 °C to +60 °C
97015-8192-19-0	DDR3L-1866	8 GByte	No ECC	0 °C to +60 °C
97015-4096-19-2	DDR3L-1866	4 GByte	No ECC	-40 °C to +85 °C
97015-8192-19-2	DDR3L-1866	8 GByte	No ECC	-40 °C to +85 °C

Global Headquarters

Kontron Europe GmbH

Gutenbergstraße 2
85737 Ismaning, Germany
Tel.: + 49 821 4086-0
info@kontron.com

www.kontron.com